



STATE OF NEW YORK
DEPARTMENT OF TRANSPORTATION
ALBANY, N.Y. 12232
www.nysdot.gov

JOAN MCDONALD
COMMISSIONER

ANDREW M. CUOMO
GOVERNOR



Introduction to Critical Path Method Scheduling using Primavera P6 8.2 Client for Construction

**Includes Analysis of Contractor's CPM Progress Schedules &
Construction Contract Administration Issues**

Developed by:

Jim Cashman, PMP

Cashman Associates, Inc.

19 Orchard Hill Rd.

Canton, CT 06019

Phone: (860) 693-6067

E-mail: jim@cashmanassociates.com

Latest Version Date of Manual: September, 2012

Revised by:

Ronald Tayam

Experis IT

Phone : (201) 602-4793

Email : ron.l.tayam@gmail.com

Introduction to Critical Path Method Scheduling using Primavera P6.1 Client for Construction

Course Purpose and Objectives

The purpose is to train project construction staff on the basic principles of project management and critical path method scheduling and how to use these tools as part of the review/acceptance of Contractor's CPM Progress Schedule submissions. The objective is to have the trained staff leave the course confident they have the knowledge and experience they can review Contractor's schedules and use the accepted Progress Schedules to manage the project and avoid, minimize, and mitigate project delays thereby completing the project on time and avoiding potential time-related disputes.

This course provides a comprehensive overview of CPM scheduling and how it is being implemented by NYSDOT for the development, review and acceptance of contractors Progress Schedule submissions. It explains how to use the Progress Schedule as a project management tool to avoid, minimize, and/or mitigate project delays and potential time-related disputes. Also included here is the guidance on using the various tools and features of Primavera P6 software to satisfy CPM scheduling specification requirements.

Introduction to Critical Path Method Scheduling using Primavera P6.1 Client for Construction

Contracts include CPM Progress Schedule requirements for several reasons:

- Ensure that the Contractor and the Department have a detailed plan and resources to complete the project in accordance with contract time requirements;
- Provide a means of monitoring the progress of work;
- Aids in communication and coordination of activities among all affected parties;
- Is required to analyze the effect of changed conditions on any milestone dates or on the contract completion date;
- Is required to analyze the effect of change orders for extra work or deductions, and unanticipated delays, on the contract completion date;
- Establishes a standard methodology for time adjustment analysis based on the principles of the Critical Path Method of scheduling, to analyze delays and resolve construction disputes concerning time;
- Is required to determine appropriate extensions or reductions of Contract Time.

Introduction to Critical Path Method Scheduling using Primavera P6.1 Client for Construction

Agenda

Day 1

Topics and Schedule:

Introductions & course goals	8:00am – 8:30am
Project Management Life Cycle	8:30am – 9:00am
Navigating in Primavera	9:00am – 9:30am
Developing the Work Breakdown Structure	9:30am – 10:00am
Break	10:00am – 10:15am
Formatting Data Layouts, views & reports	10:15am – 11:00am
Calendars	11:00am – 11:30pm
Activity Codes	11:30am – 12:00pm
Lunch	12:00pm – 1:00pm
Group, Sort, & Filter activities	1:00pm – 2:00pm
CPM Scheduling Concepts	2:00pm – 3:00pm
Break	3:00pm – 3:15pm
Analyzing Relationships	3:15pm – 4:00pm
Q&A	4:00pm – 4:30pm

Day 2

Topics and Schedule:

Summary from Day 1	8:00am – 8:15am
Evaluating Constraints	8:15am – 8:45am
Resource Analysis/Production Rates	8:45am – 9:15am
Optimizing the Project Plan	9:15am – 10:00am
Break	10:00am – 10:15am
Optimizing the Project Plan (continued)	10:15am – 11:00am
Using the Baseline feature	11:00am – 12:00pm
Lunch	12:00pm – 1:00pm
Reviewing the Progress Schedule Submission	1:00pm – 3:00pm
Break	3:00pm – 3:15pm
Using Claim Digger	3:15pm – 3:45pm
Reporting Project Performance	3:45pm – 4:15pm
Q&A	4:15pm – 4:30pm

Introduction to Critical Path Method Scheduling using Primavera P6.1 Client for Construction

This course includes the following lessons:

	Page
• Lesson 1 - Project Management Life Cycle	9
• Lesson 2 - Navigating in Primavera P6	16
• Lesson 3 - Understanding WBS	29
• Lesson 4 - Working with Activities	36
• Lesson 5 - Customizing Project and Activity Data Layout	45
• Lesson 6 - Analyzing Relationships	63
• Lesson 7 - CPM Scheduling Concepts	74
• Lesson 8 - Evaluating Constraints	87
• Lesson 9 - Resource Analysis /Production Rates	94
• Lesson 10 - Optimizing the NYSDOT Project Plan	107
• Lesson 11 - Baselining the Project Plan	113
• Lesson 12 - Monthly Progress Schedule Submissions	119
• Lesson 13 - Reporting Performance	134
• Appendix – NYSDOT CPM Specification	139

Introduction to Critical Path Method Scheduling using Primavera P6.1 Client for Construction

The course introduces you to CPM Scheduling and the software application, Primavera P6. At the completion of this course, you will be able to:

- Understand the key building blocks of a CPM Schedule and the various software tools that help to organize the schedule and create reports**
- Understand how the CPM Progress Schedule is used both as a Project Management and Program Management tool**
- Understand the differences between Project data and tools as compared to Enterprise data and tools**
- Understand the requirements of the CPM Scheduling specifications and how to review the contractor's Progress Schedule submissions**

Introduction to Critical Path Method Scheduling using Primavera P6.1 Client for Construction

NYSDOT has selected Primavera P6 which is a multi-user web enabled application that can provide the Department comprehensive information at a program (multi-project) level through executive summaries, and also at the project level through detailed activity views for field office staff using a Department wide enterprise database located on network servers.

Primavera P6 is an integrated solution with Department users located in the Main Office or Regional Offices having access to the Client through an Icon on their desktop or through CITRIX or to the WebPM through Internet Explorer, and Construction Field Office users having access to the Client tool through CITRIX or the WebPM tool through Internet Explorer. Consultant and Contractor users have access to the Client tool through CITRIX. The software tools are role specific to satisfy each team member's needs, responsibilities, and skills. This provides NYSDOT a common platform for NYSDOT program area managers, NYSDOT field office staff, Contractors and Consultants.

Primavera is an enterprise-wide solution.

- **Works identically in single and multi-project modes.**
- **Scalable client/server architecture.**
- **Relational databases: Oracle (which is used by NYSDOT), SQL Server or MSDE.**

Introduction to Critical Path Method Scheduling using Primavera P6.1 Client for Construction

Lesson 1:

The Project Management Life Cycle

Objectives

This lesson provides an overview of how the Primavera software tool can assist in the various stages of the project management life cycle. At the completion of this lesson, you will be able to:

- **Review the relationship between the various Primavera software features and the project management life cycle.**
- **Identify the five process groups in the project management life cycle.**
- **Identify your NYSDOT role in the project management life cycle.**

Introduction to Critical Path Method Scheduling using Primavera P6.1 Client for Construction

Project Management Life Cycle

Project management is the process of achieving set goals within the constraints of time, budget and staffing restrictions.

Lessons in this curriculum will cover the processes applicable to the development, review and acceptance of progress schedules.

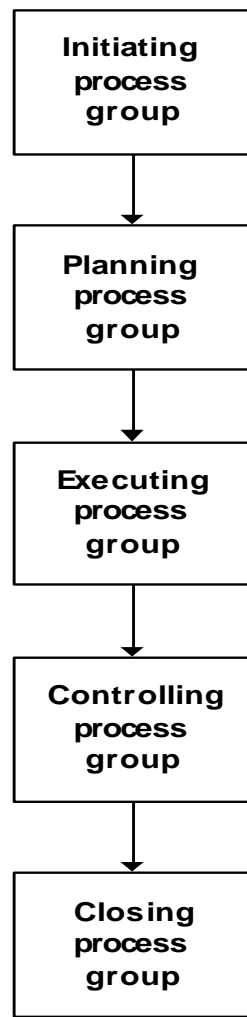

Introduction to Critical Path Method Scheduling using Primavera P6.1 Client for Construction

Project Management Life Cycle (*continued*)

Each process can be broken down into these steps:

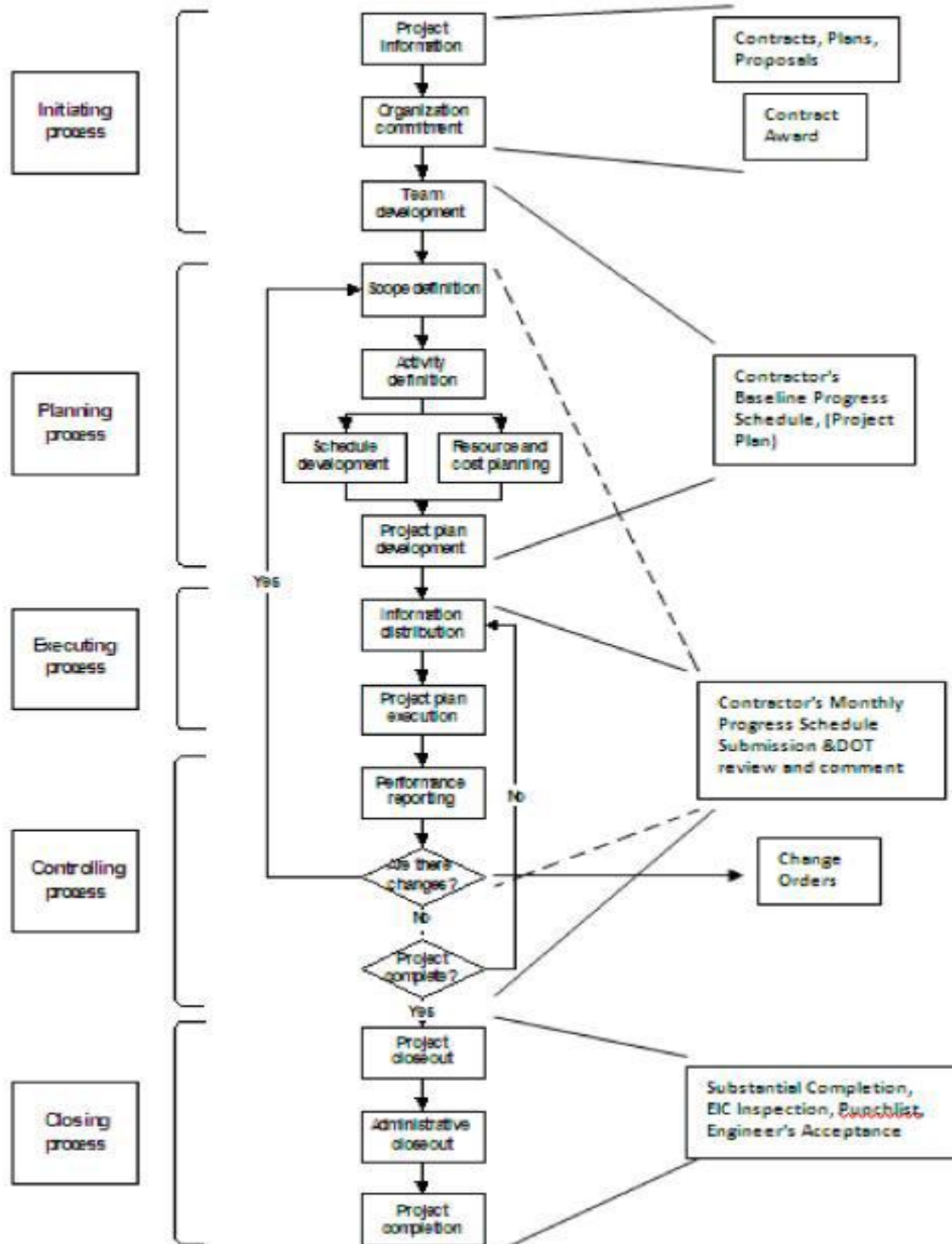

Introduction to Critical Path Method Scheduling using Primavera P6.1 Client for Construction

Planning Process Group (Contractor's Baseline)

- **Develop project plan (schedule) using contract documents**
- **Develop team (Subcontractors, Fabricators, crews, and supervisory staff)**
- **Create project work activities**
- **Determine the work sequence and duration**
- **Establish resource requirements/availability**
- **Evaluate, optimize, and submit baseline**

Excerpt from Paragraph A. Project Scheduler:

The Contractor shall designate an individual, entitled the Project Scheduler, who will develop and maintain the construction progress schedule. The Project Scheduler shall be present at the Preconstruction Schedule Meeting, prepared to discuss, in detail, the proposed sequence of work and methods of operation, and how that information will be communicated through the Progress Schedule. The Project Scheduler shall attend all meetings, or receive meeting minutes that outline schedule related issues of those meetings, which may affect the CPM schedule, including but not limited to those between the Contractor and their Subcontractors and between the Contractor and the Department. The Project Scheduler shall be knowledgeable of the status of all aspects of the work throughout the length of the Contract, including but not limited to: original contract work, additional work, new work, and changed conditions of work.

Excerpt from Paragraph D.1. (Progress Schedule):

The Contractor will be the sole entity allowed to physically modify the following data within the progress schedule: activity IDs; activity descriptions; activity durations; relationships between activities; successors and predecessors, actual start and actual finish dates of activities; planned start and planned finish dates of activities; and activity resources.

NYSDOT Project Field Office Staff will review and analyze the submitted baseline progress schedule from the Contractor to verify that it conforms to the contract document requirements. This includes the relevant CPM Special Specification, Special Notes, Section 100 of the Standard Specifications, and any Time-Related contract provisions.

Introduction to Critical Path Method Scheduling using Primavera P6.1 Client for Construction

Controlling Process Group (Contractor and DOT)

- **Contractor updates the project plan (Monthly Progress Schedule submissions) to reflect Actual Start and Actual Finish of work activities, changes to sequencing of activities, and activity logic and duration**
- **DOT verifies progressed work activities Actual Start and Actual Finish dates and Remaining Duration using inspection reports or other project records**
- **DOT and contractor adjust the project plan to stay on schedule**
- **Reschedule the project**
- **Communicate project performance to the project team**

Excerpt from Paragraph D, 4, b.(Monthly Progress Schedule Submission):

- b) **Subsequent Monthly Progress Schedule Submissions** - On a monthly basis, the Contractor shall submit a copy of the current Progress Schedule that includes all Progress Schedule Revisions and Progress Schedule Updates to reflect the actual and planned prosecution and progress of the contract work. Progress Schedule Updates shall reflect the status of activities that have commenced or have been completed, including the following items: (a) actual dates in activity Actual Start and Actual Finish columns as appropriate; (b) actual Remaining Duration for activities commenced and not complete; and (c) actual activity Suspend or Resume dates for activities commenced and not complete. Progress Schedule Revisions reflect modifications made to activities in the current project baseline schedule in any of the following items: (a) activity Original Duration; (b) changes in logic connections between activities; (c) changes in Constraints; (d) changes to Activity Descriptions; (e) activity additions or deletions; (f) changes in Activity Code assignments; (g) changes in activity Resource assignments; and (h) changes in Calendar assignments.

Introduction to Critical Path Method Scheduling using Primavera P6.1 Client for Construction

Excerpt from Paragraph E.1.4 (Progress Schedule Review and Analysis):

1. Immediate Rejection of Progress Schedule Submissions.

The following deficiencies in a Contractor's progress schedule submission shall be grounds for the immediate rejection by the EIC, without further review, analysis and/or comments.

- a) Failure of the Project Scheduler to "schedule" the project, as of the data date.
- b) Failure to attach a copy of the complete Scheduling/Leveling Report (SCHEDLOG.TXT file generated by Primavera software application).
- c) Any activities without predecessors, or activities without successors, appearing in the Scheduling/Leveling Report with the exception of the first and last activity in the schedule.
- d) Any activity constraints appearing in the Scheduling/Leveling Report that have not been approved in writing by the EIC, or that are not specifically allowed by this specification.
- e) Any Activities with Actual Dates > Data Date appearing in the Scheduling/Leveling Report.
- f) Any Milestone Activities with invalid relationships appearing in the Scheduling/Leveling Report.
- g) Failure to have a clearly defined Critical Path from the Data date to the last activity in the schedule, using the Longest Path method. This would reflect logic errors in the project schedule.
- h) Failure to attach the schedule Narrative and required appendices.
- i) Failure to attach the Claim Digger Report (generated by the Department's Primavera scheduling software application) providing a comparison between this Progress Schedule submission and the previous Progress Schedule submission. (Not required for baseline submissions)

If any of these deficiencies are found, the Contractor's submission shall be considered deficient, and Engineer will notify the Contractor immediately by return E-mail of the rejection of the schedule submittal.

4. Department Review and Acceptance of Progress Schedules.

The Engineer will review the Monthly Progress Schedule submissions and will prepare a written response (Progress Schedule Review Report) to the Contractor's submission within five (5) State Business Days following receipt of the Contractor's complete schedule submission. The Engineer will either "accept" the schedule, "accept as noted", or "reject" the schedule for re-submittal by the Contractor.

If the Progress Schedule submission is not in compliance with contract requirements, the Engineer may reject the submittal and shall forward any comments and requests for schedule revisions to the Project Scheduler with a copy to the Contractor. The Project Scheduler shall address all comments in writing and/or make the requested revisions, and resubmit the revised schedule within three (3) State Business days of the Engineer's reply. If the Engineer determines the revised submission still does not meet the contract requirements, any further revisions required thereafter shall also be submitted for acceptance within (3) business days of the request for revisions by the Engineer.

Introduction to Critical Path Method Scheduling using Primavera P6.1 Client for Construction

Lesson 1: The Project Management Life Cycle

Review Questions

1. What party is responsible for developing the project plan?
2. What does the **Controlling Process Group** in the project management life cycle represent in the NYSDOT schedule process?
3. Paragraph **D. 4. Monthly (Progress Schedule Submission)** falls under what process of the project management life cycle? Why?
4. **True or False:** According to paragraph **E.1.4 (Progress Schedule Review and Analysis)** of the CPM Special Specification “when any deficiencies are found, the Engineer will notify the Contractor after 5 days about the schedule submittal rejection”.
5. How can CPM scheduling be useful in monitoring and ensuring that projects complete successfully?

Introduction to Critical Path Method Scheduling using Primavera P6.1 Client for Construction

Lesson 2:

Navigating in Primavera P6

Objectives:

In this lesson, you will be introduced to the basic functions and features of Primavera P6. At the completion of this lesson, you will be able to:

- **Log in**
- **Open and close an existing project**
- **Navigate the Home and Activities windows**

Excerpt from Paragraph B. (Scheduling Software):

Project schedules are developed from the Contractor's knowledge of the project, and the means and methods represented in those schedules are based on the Contractor's understanding of the contract documents, and the Contractor's past experience, which are unique to the Contractor. Schedule activity data and logic are therefore the intellectual property of the Contractor and will not be made available to other Contractors. All other schedule data, and all Enterprise data residing on the network servers, are the sole property of the Department

Introduction to Critical Path Method Scheduling using Primavera P6.1 Client for Construction

Logging In: Citrix

Initial login to the NYSDOT server will be through Citrix remote access. Once you are logged on the server, you will then access Primavera.

[Excerpt from Paragraph B. \(Scheduling Software\):](#)

Primavera software and schedule data on the Department's EPMD will generally be available for the Contractor's use at all times unless system maintenance (i.e. backups, upgrades, etc) is being performed. System maintenance will generally be conducted over short time periods between the hours of 10 PM – 6AM, Monday - Friday and on weekends. The Department does perform regular backup of data contained in the EPMD, and will make every effort to restore the latest historical copy of schedule submissions in the event of any data failure of the EPMD. The Contractor shall also be responsible for exporting copies of project progress schedules, recovery schedules, TIA schedules, after data modifications have been made as their backup of these submissions. In the event a Contractor's authorized user cannot access the software from 6AM to 10PM Monday through Friday, the Contractor shall provide written notification to the Engineer.

Steps:

1. Access the NYSDOT Citrix website: <http://www.nysdot.gov/citrix>
2. Enter your **Citrix user name** and **password**
3. After a successful login, select the Primavera application icon. For training, click **“Test - Primavera 6I for Construction.”** For production project reviews, click **“Primavera 6I for Construction.”**

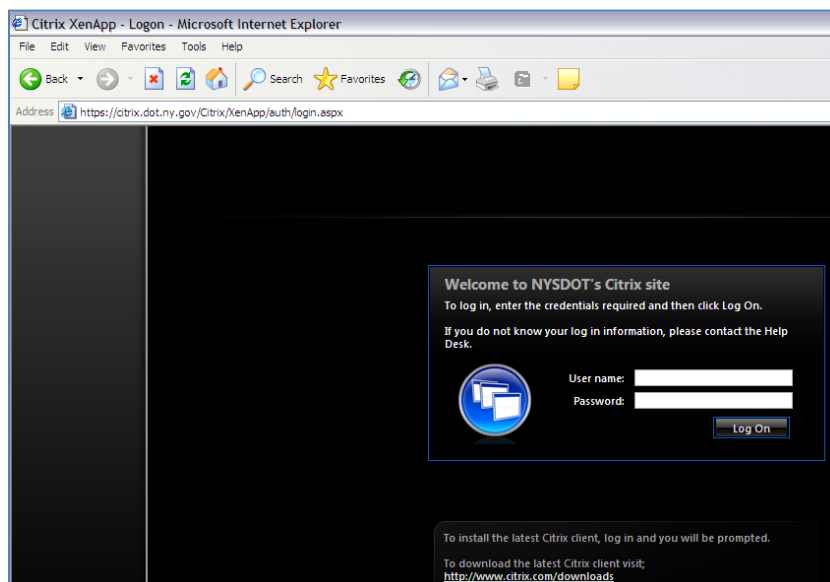

Introduction to Critical Path Method Scheduling using Primavera P6.1 Client for Construction

Logging In: Primavera

Before using Primavera, you must enter a valid login name and password. If you do not know your login name and password, contact your NYSDOT system administrator.

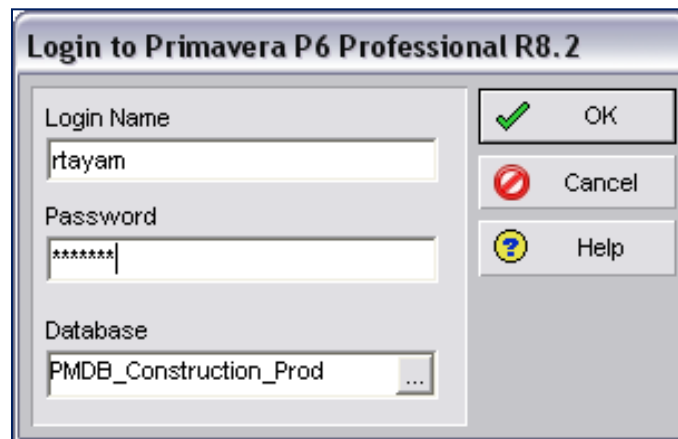

Steps:

1. Click **Start, Programs, Primavera, Project Management** (only when installed locally)
2. Type in your assigned **Login Name** and **Password**. During training, these will be provided for you. For production project reviews, the *Office of Construction* will provide you a user login name upon request and supervisory approval.
3. Under **Database**, select **"PMDB_Construction_Dev"** for training. For production, select **"PMDB_Construction_Prod."**
4. Click **OK**

Note: ***User names and passwords ARE case-sensitive!***

Introduction to Critical Path Method Scheduling using Primavera P6.1 Client for Construction

Welcome Dialog Box

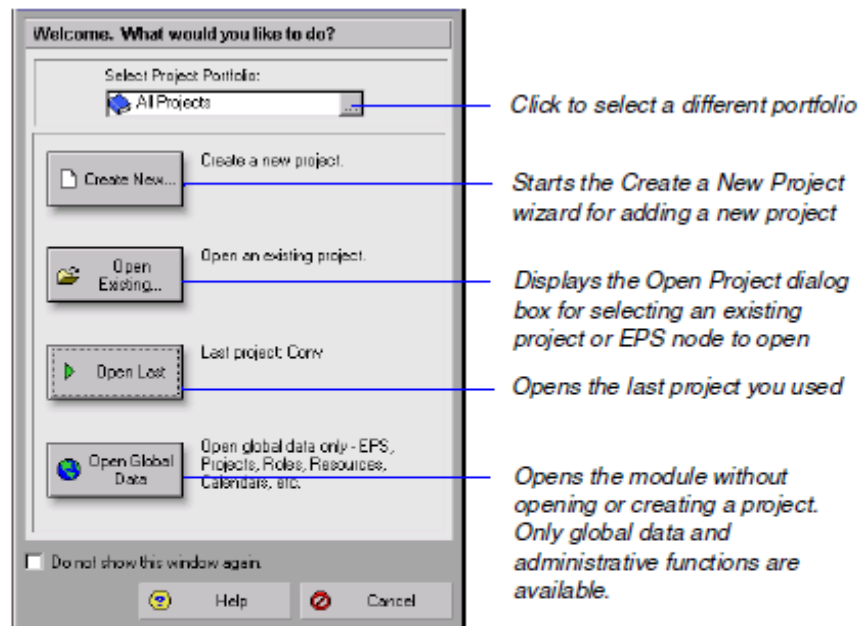

Mark the Do Not Show This Window Again checkbox if you do not want the Welcome dialog box to appear each time you open the module. The last project used at startup automatically opens. To turn this option back on, choose Edit, User Preferences, then click the Application tab and mark the Show the Welcome Dialog at Startup checkbox.

Introduction to Critical Path Method Scheduling using Primavera P6.1 Client for Construction

Main Window

The main window is your starting point for navigating through various windows.

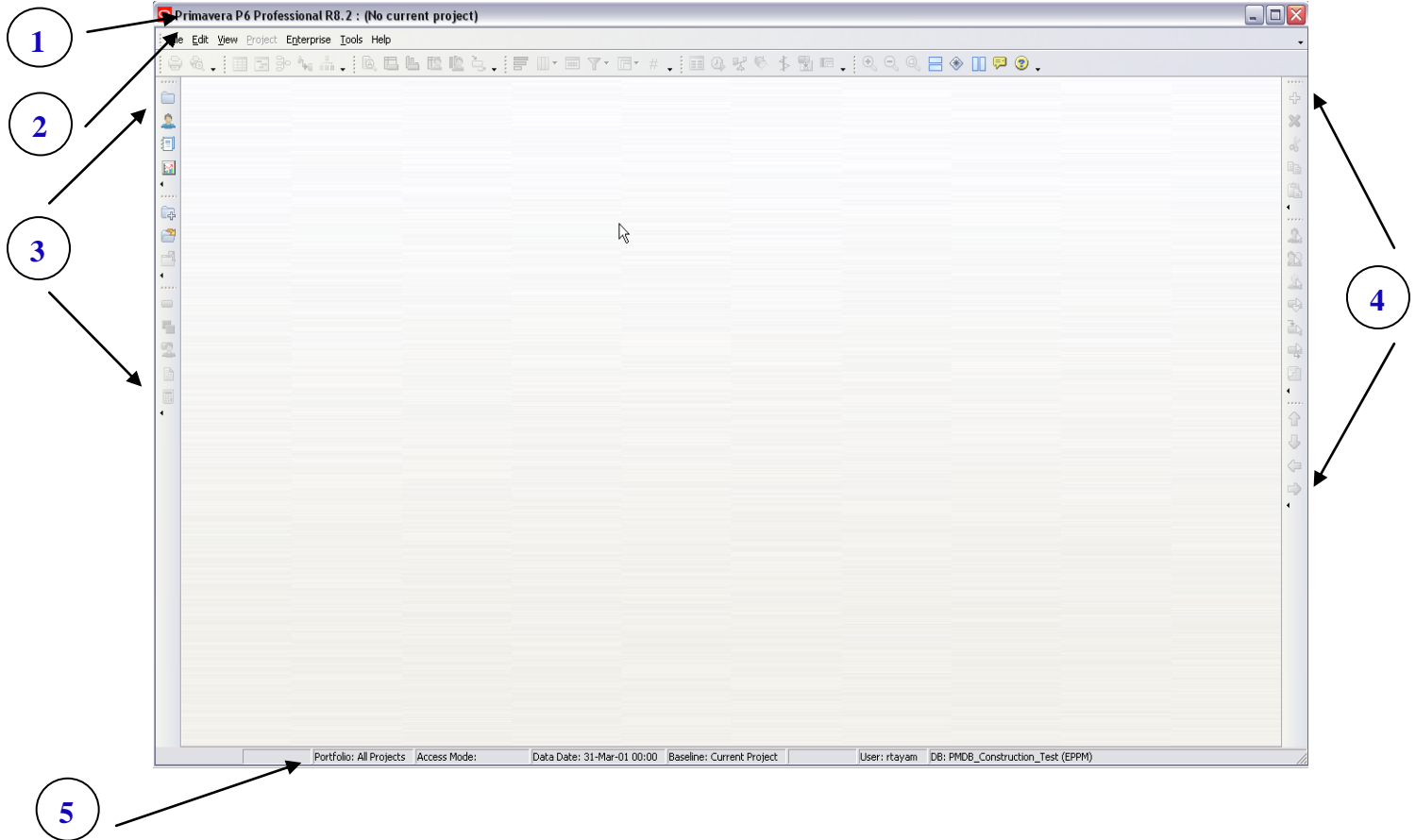

Item	Functionality
1. Title Bar	Displays current application and name of open projects.
2. Menu Bar	Performs functions and features in Primavera
3. Directory Bar	Quickly displays and switches Primavera Windows
4. Command Bar	Performs activity addition, changes and revisions
5. Status Bar	Displays user's login name, data date of open projects, access mode, and current baseline.

Introduction to Critical Path Method Scheduling using Primavera P6.1 Client for Construction

Directory Bar

Use the Directory Bar to display different data windows quickly by switching between the icons below:

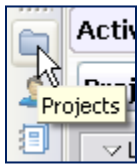

- to View Projects window

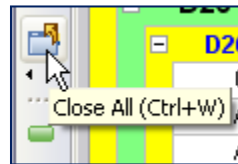

- to Close all projects

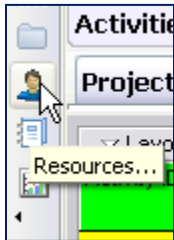

- to View Resources



- to Go to Activities window

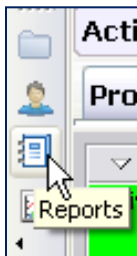

- to Print Reports



- to Go to the WBS window

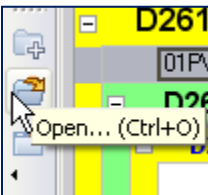

- to Open an existing project

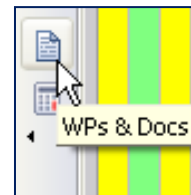



- to Create Work Products and Project Documents

Introduction to Critical Path Method Scheduling using Primavera P6.1 Client for Construction

Opening an Existing Project

The open project dialog box lists all the projects you have access to open.

- Open a single project, indicated by 
- Open a single node, indicated by 
 - All projects under the node are opened.
- Open multiple projects under different nodes.
 - Press **Ctrl+click** to select more than one project.

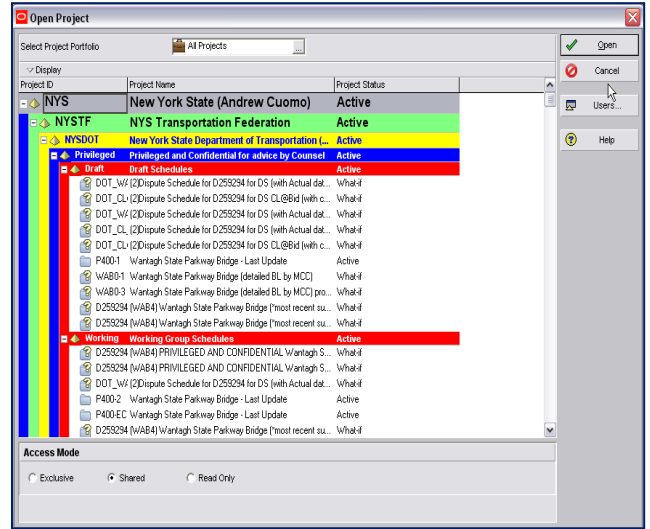

Steps:

1. In the **Directory Bar**, click the **Projects** button.
2. At the **File** menu, click **Open**. At **Open a Project** box, click **Open**.

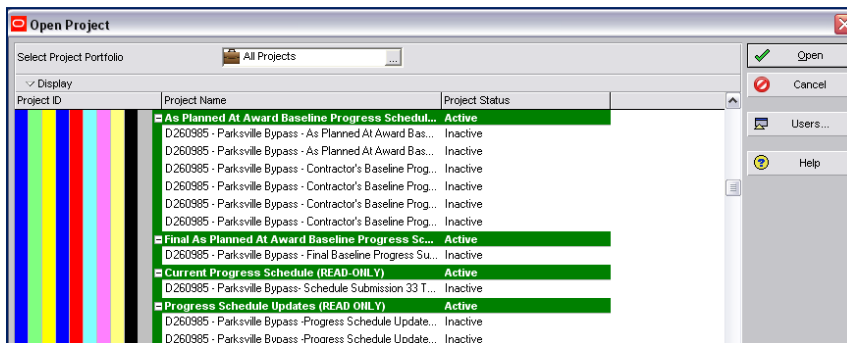

Access Modes

You have the option to select and access mode prior to opening a project:

Read Only

- View data, but cannot input or change data.

Shared

- Multiple users can view, input, and change data.
- This is the default setting.

Exclusive

- Current user is the only user who can edit data.
- Other users can access the project in *Read Only* mode.

Introduction to Critical Path Method Scheduling using Primavera P6.1 Client for Construction

Closing a Project

You should close the project when you are finished working with it. You are prompted to verify that you want to close the project.

Closing the project takes you back to the Home window.

Steps:

1. In the **File** menu, click **Close All**.

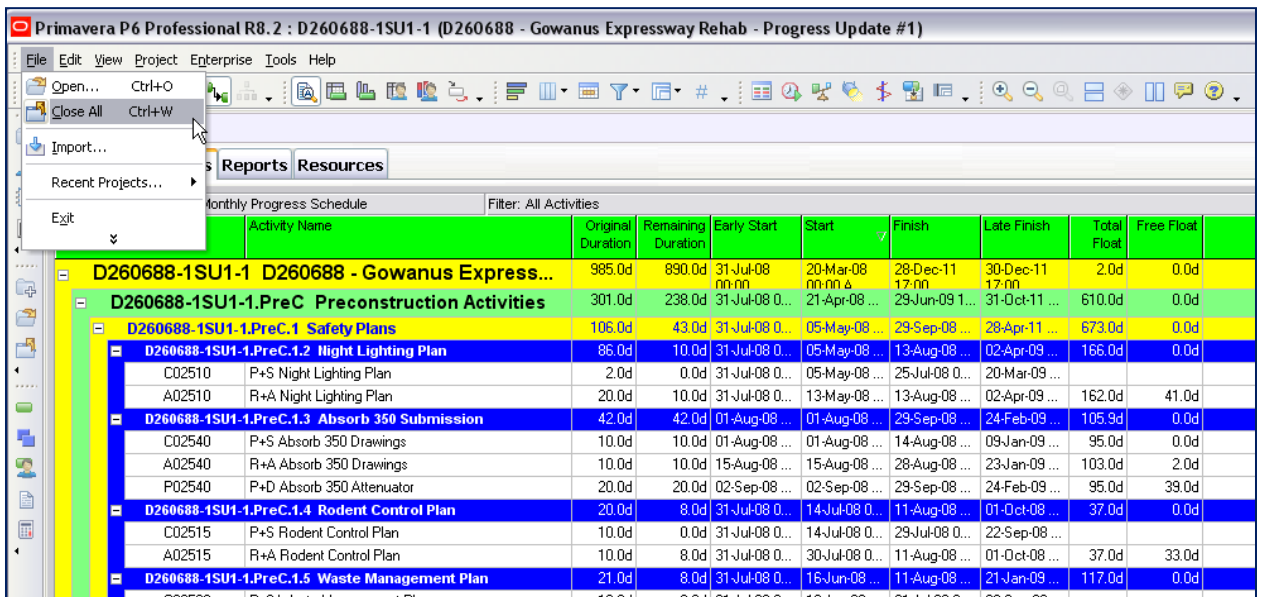

2. When prompted, click, **Yes**.

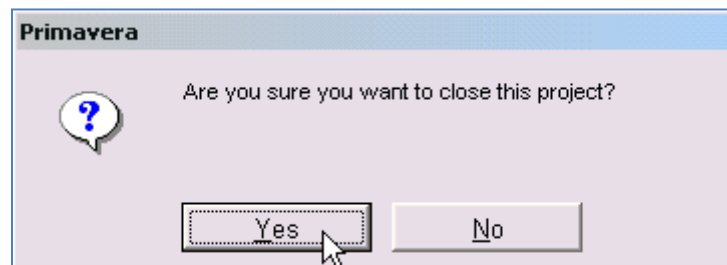

Introduction to Critical Path Method Scheduling using Primavera P6.1 Client for Construction

Activities Window

The Activities window is used to create, view, and edit activities for open projects. It can be divided into a top and bottom layout.

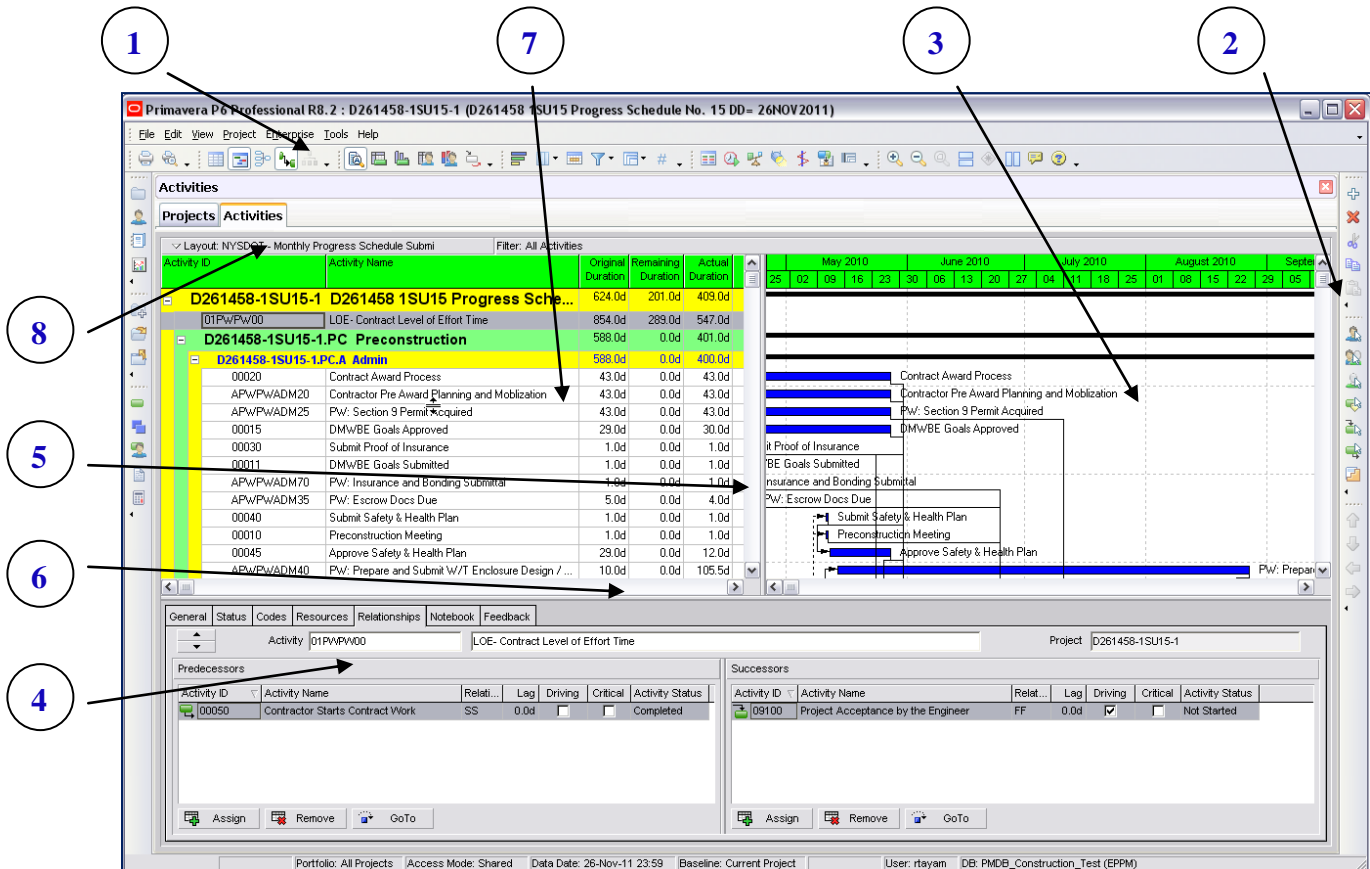

Item	Functionality
1. Toolbar	Displays icons that allow you to change look of layout.
2. Command Bar	Displays options for adding or removing activity data.
3. Gantt Chart	Provides graphical display of activity progress over time.
4. Activity Details	View/edit detailed information for selected activity
5. Horizontal Split Bar	Hide or show more information in top/bottom layouts.
6. Vertical Split Bar	Drag Bar to hide/show more information in each pane.
7. Activity Table	Displays activity information in spreadsheet format.
8. Layout Options Bar	Displays menu of available options for Activities window.

Introduction to Critical Path Method Scheduling using Primavera P6.1 Client for Construction

New Functions in Release 8.2

Progress Line

Apply a Progress Line to the Gantt chart to quickly enable you to view the progress of activities with regard to their scheduled deadlines.

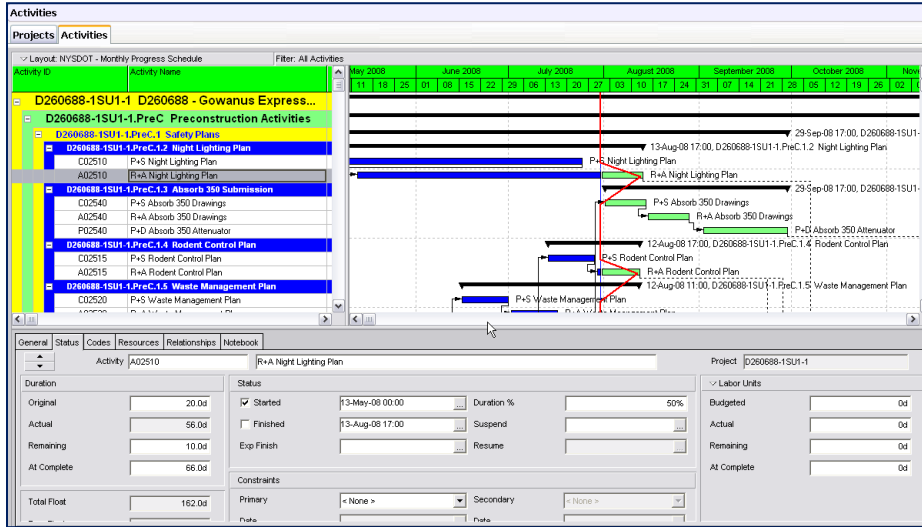

Line Number

Add line numbers to number each row in the Activities view.

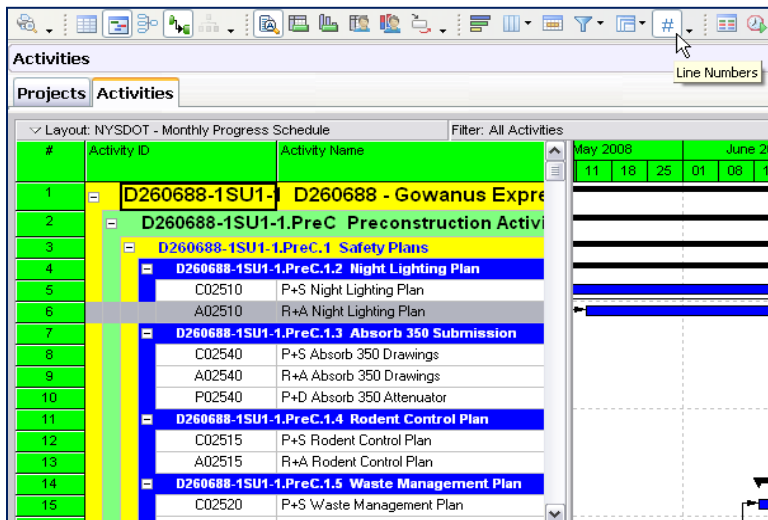

Introduction to Critical Path Method Scheduling using Primavera P6.1 Client for Construction

Update Progress

Use the Update Progress dialog box to update the durations and actual values of the selected activities.

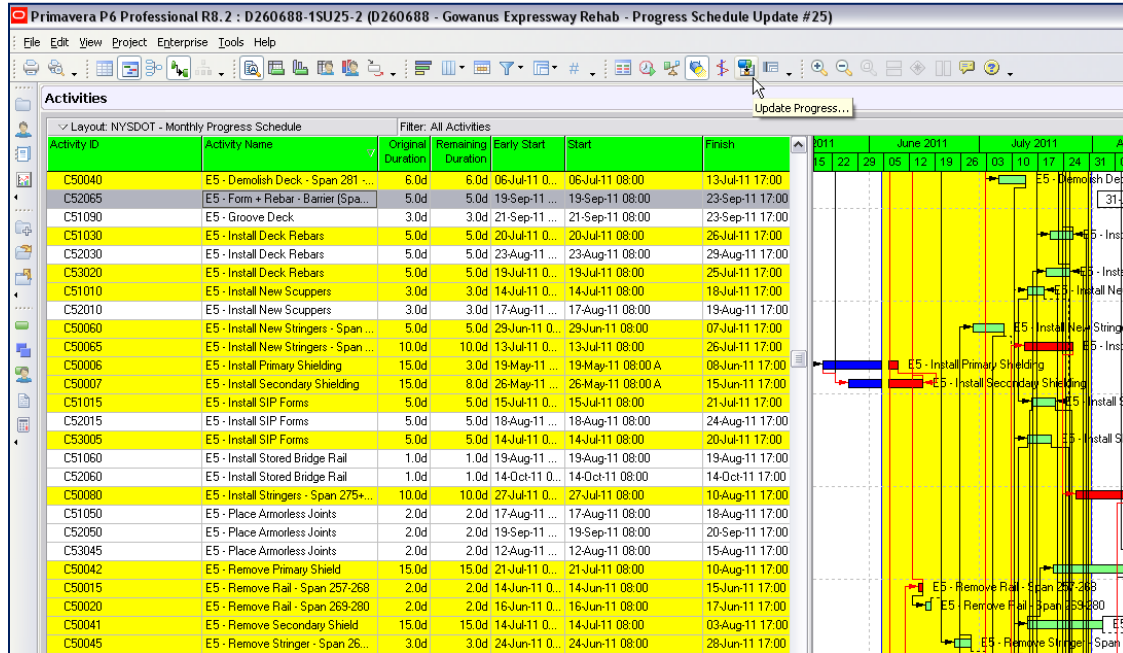

Update Progress

Current Data Date
04-Jun-11 07:01

New Data Date
31-Jul-11 13:40

When using progress spotlight update progress for

All highlighted activities

Selected activities only

When actuals are applied, calculate activity remaining durations:

Based on activity duration type

Always recalculate

Apply
Cancel
Help

Introduction to Critical Path Method Scheduling using Primavera P6.1 Client for Construction

Attachments

Use Curtain or Text to highlight visual areas of the Gantt chart.

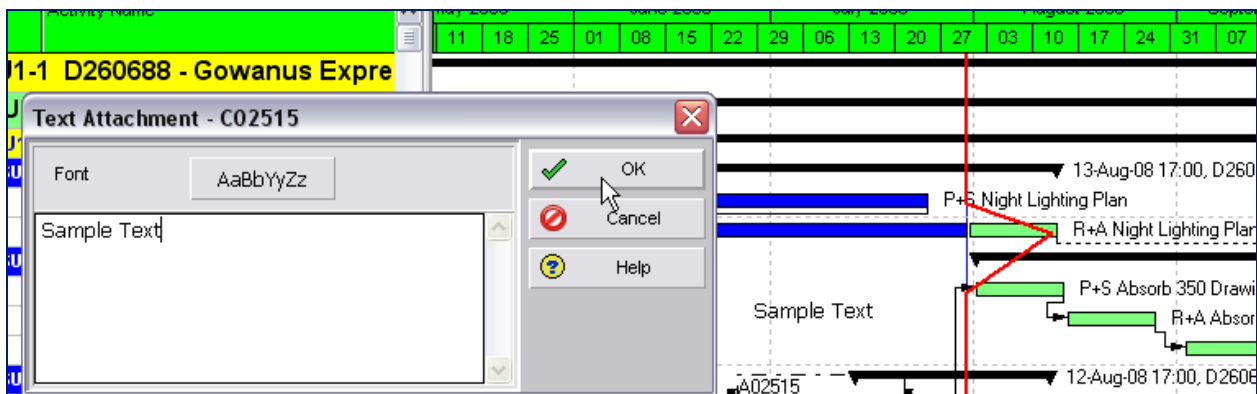
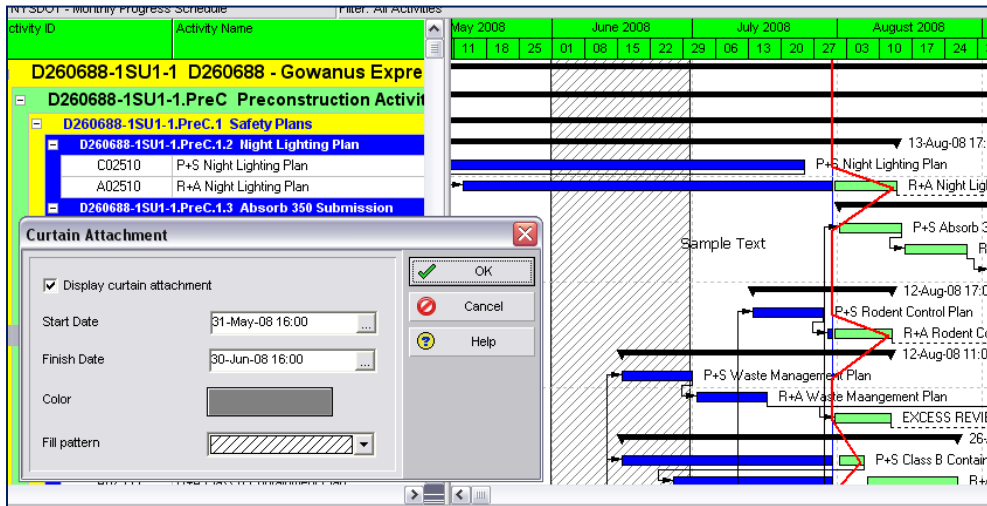
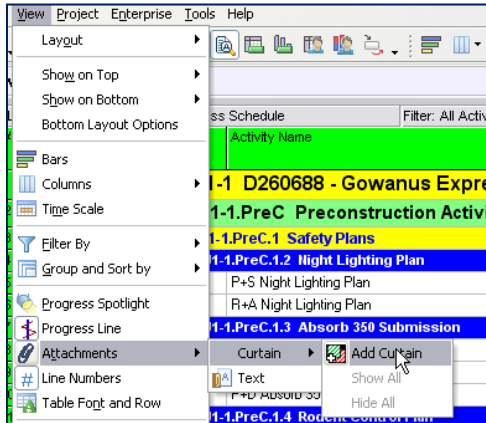

Introduction to Critical Path Method Scheduling using Primavera P6.1 Client for Construction

Lesson 2: Navigating in Primavera

Review Questions

1. In Primavera, when you're on the **Project** layout, how do you know that you have opened the right project?
2. How do check if you are in **Project** or **Activity** window?
3. Why is the Activity button grayed-out when you are in the Home window or Main menu?
4. You just opened a project. How can you tell what **Access Mode** you are given for the project?

Introduction to Critical Path Method Scheduling using Primavera P6.1 Client for Construction

Lesson 3:

Understanding WBS

Objectives

This lesson provides the understanding of the importance and functions of the Work Breakdown Structure (WBS).

At the completion of this lesson, you will be able to:

- **Understand how a project's deliverables are organized within the WBS**

Introduction to Critical Path Method Scheduling using Primavera P6.1 Client for Construction

What is a WBS?

Work Breakdown Structure is a hierarchical arrangement of the products and services produced during and by the project. The project is the highest level while an individual activity (or an action item) to create a product or service is at the lowest level.

Excerpt from Paragraph 2. (Baseline Progress Schedule @ Award):

- iii) **Work Breakdown Structure (WBS)** - A multi level hierarchal WBS shall be incorporated. The levels (nodes) shall include, but not be limited to:
 - Level 1 - is the project level;
 - Level 2 - shall have three nodes; Preconstruction Activities, Construction Activities, and Post Construction Activities;
 - Level 3 - Preconstruction activities shall have two sub nodes; Submittals/Shop Drawing Activities, and Procurement /Fabrication Activities);
 - Construction activities shall be broken into nodes for various geographic “Areas” of work within the project limits;
 - Level 4 - the Areas of work shall have sub nodes for the various Stages of work;
 - Level 5 - the Stages of work shall have sub nodes for the various highway features: bridges, highway segments, interchanges, intersections/roundabouts, etc;
 - Level 6 - the highway features should be broken into their components (a bridge into components such as Piles, Substructure, Superstructure), and a highway segment into components such as pavement, drainage, earthwork, lighting, traffic signals, etc.

As an example, one product of an NYSDOT project could be a new bridge. One node of the WBS will represent this as “product” or “deliverable” for the project. All work activities to build the bridge would be assigned to this WBS node. The software then summarizes the total of all the activities under this node to allow the user to see what effort is required to build the bridge. If sub nodes are included under this node, the work will be broken up into various components such superstructure, substructure, deck, etc. Then, these sub nodes will summarize the work activities assigned to each of them.

Introduction to Critical Path Method Scheduling using Primavera P6.1 Client for Construction

NYSDOT Standard Work Breakdown Structure

The NYSDOT Work Breakdown Structure (WBS) is a hierarchical arrangement of the deliverables produced during and by a project. It enables you to divide a project into meaningful and logical pieces for the purpose of planning and control. NYSDOT has developed a template for baseline project schedule.

- Each project has a unique WBS hierarchy.
 - The root level of the WBS is equal to the project ID and name.
- Elements within the WBS have a “child/parent” relationship, which means that you can roll up and summarize information from the lower levels.

Steps:

1. Select **File, Open, All Projects**; click the **Open** button.

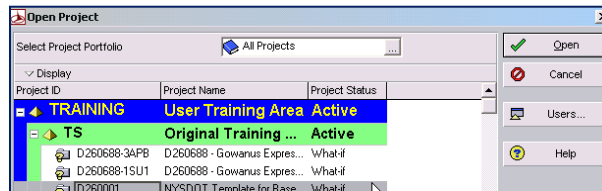

2. In the **Directory Bar**, click on the **WBS** button.

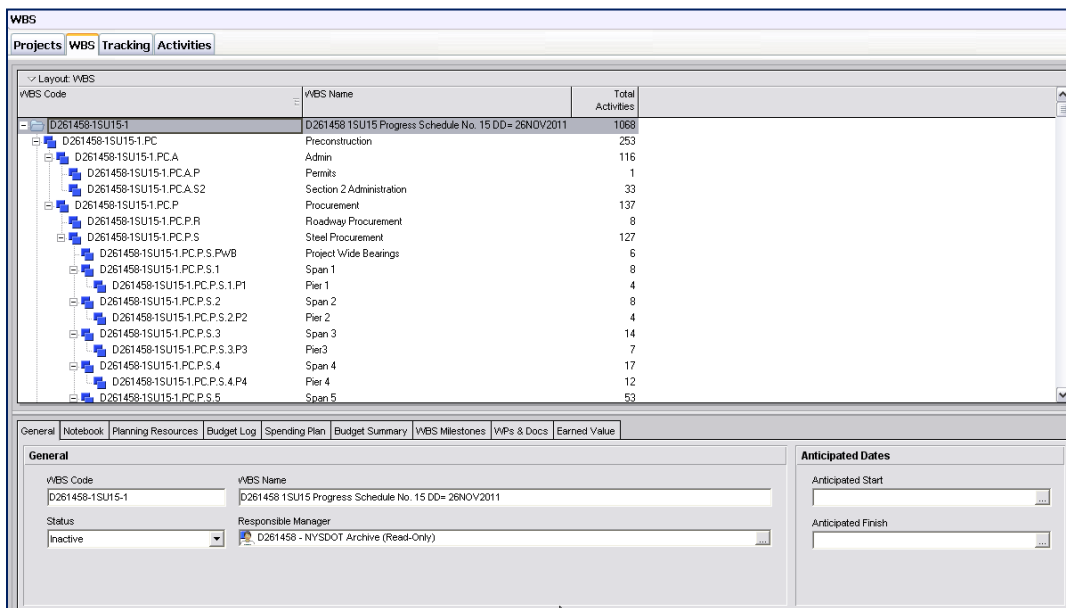

Introduction to Critical Path Method Scheduling using Primavera P6.1 Client for Construction

Lesson 3: Understanding the WBS

Review Questions

1. In your words, explain **WBS** (*Work Breakdown Structure*).
2. Why is the **WBS** an important component in planning the CPM Schedule?
3. In what **WBS** level are the project's **Stages** placed, according to the NYSDOT CPM Specification? How does the misplacement of Stages or Areas impact the breakdown of the work activities?
4. In the **EPS**, what is the significance of putting the nodes for the Regions above the nodes for the projects?

Introduction to Critical Path Method Scheduling using Primavera P6.1 Client for Construction

Lesson 4:

Working with Activities

Objectives

In this lesson, you will learn the features and details of the Activities view. At the completion of this lesson, you will be able to:

- **Explain activity components, types and detail tabs**
- **Differentiate between primary activity data versus secondary activity data**
- **Examine an activity's calendar assignment**

[NYSDOT requires that the Contractor provides a detailed CPM schedule for their project.](#)

[Excerpt from Paragraph 2.d, ii \(Baseline Progress Schedule @ Award\):](#)

ii) Sufficient activities shall be included to assure that there was adequate planning for the entire project. The appropriate number of activities will be largely dependent upon the nature, size, and complexity of the project. In addition to all site construction activities, network activities shall include: activities necessary to depict the procurement/submittal process including shop drawings and sample submittals, and the fabrication and delivery of key and long-lead procurement elements; activities assigned to subcontractors, fabricators, or suppliers; activities assigned to the Department and other involved State agencies and authorities; punch list activities; close out activities; and activities assigned to other entities such as utilities, municipalities, County government/agencies, and other adjacent contractors. The schedule shall indicate intended submittal dates, and depict the review and approval periods as defined in the Contract Documents for Department review.

Introduction to Critical Path Method Scheduling using Primavera P6.1 Client for Construction

Working with Activities (*continued*)

As part of your schedule review, you will evaluate the detailed activity list that describes how the contractor will conduct their work. Your expertise in the construction process will be your guide to the validity of the schedule.

Suggestions for evaluating activities:

- Are the activities listed in enough detail?
 - Activities should not be more than 15 days long.
 - There may be some acceptable exceptions.
- Activities should have only one responsible organization.
 - For example: Contractor, NYSDOT, Utilities, other agencies
- Activities should include all phases of work including:
 - Submittals, procurement, fabrication, construction, etc.
- Do the activities meet the specification requirements?

Activity Components:

Optional



Mandatory

Note: When creating an Activity, all components on the **Mandatory** side are required. *WPs & Docs* are optional for now but will be a part of requirements in the future.

Introduction to Critical Path Method Scheduling using Primavera P6.1 Client for Construction

Activity Details

All of the activity components can be accessed through the *Activity Details* form and the *details tabs*.

The screenshot shows the 'Activity Details' form in Primavera P6.1. The form is divided into several sections. At the top, there are tabs for 'General', 'Status', 'Codes', 'Resources', 'Relationships', 'Notebook', and 'WPs & Docs'. The 'General' tab is selected. The form displays the following information:

- Activity: CS1S1GDF10
- Project: D261458-1SU15-1
- Activity Calendar: D261458 - Steel Erection
- Task Type: Task Dependent
- Duration Type: Fixed Duration & Units
- Duration: [blank]
- % Complete Type: [blank]
- MBS: D261458-1SU15-1.C.ID.S.S1.SS.S1.D Decking
- Responsible Manager: D261458 - NYSDOT Archive (Read-Only)
- Primary Resource: MD-1 Metal Deck Crew 1

Excerpt from Paragraph D.4. (Progress Schedule, 1. General):

The Contractor will be the sole entity allowed to physically modify the following data within the progress schedule: activity IDs; activity descriptions; activity durations; relationships between activities; successors and predecessors, actual start and actual finish dates of activities; planned start and planned finish dates of activities; and activity resources (with the exception that activities assigned resources labeled to reflect Department personnel may be changed to reflect specific individuals, or job roles, within the Department).

Activity Types:

Start Milestone

- Typically used to mark the beginning of a phase or to communicate project deliverables.
- Zero duration activity.
- **Only has a start date.**
- Can assign constraints, expenses, work products, and documents.
- Can assign a primary resource.
- Cannot assign roles or resource assignments

Introduction to Critical Path Method Scheduling using Primavera P6.1 Client for Construction

Finish Milestone

- Typically used to mark the end of a phase or to communicate project deliverables.
- Zero duration activity.
- **Only has a finish date.**
- Can assign constraints, expenses, work products, and documents.
- Can assign a primary resource.
- Cannot assign roles or resource assignments.

Task Dependent

- Typically used when the work needs to be accomplished in a given time frame, regardless of the assigned resources' availability.
- The activity's resources are scheduled to work according to the activity calendar.
- Duration is determined by the assigned calendar's workweek.

NOTE: *This is the default activity type and will be the primary type for NYSDOT projects.*

WBS Summary

- Compromises a group of activities that share a common WBS level.
- Dates calculated are based on the earliest start date and the latest finish date of the activities in the group.
- Duration is calculated based on the assigned calendar.
- Cannot assign constraints
- NYSDOT may use this type to assign resources and costs.

Level of Effort

- Typically used for ongoing tasks dependent on other activities.
- Duration is determined by its predecessor/ successor activities.
- Clerical work, security guard, meetings, and project management tasks.
- Cannot assign constraints.

Resource Dependent

- Typically used when multiple resources assigned to the same activity can work independently.
- The activity's resources are scheduled according to their individual resource calendar.
- Duration is determined by the availability of the resources assigned to work on the activity.

Introduction to Critical Path Method Scheduling using Primavera P6.1 Client for Construction

Status Tab

Use the Status Tab to define or view the selected activity's duration, constraint, start and finish dates, labor and non-labor units and costs, and material costs. You can also use the Status tab to view the selected activity's *float*, *actuals*, and *remaining duration*.

The screenshot shows the 'Status' tab in the Primavera P6.1 client. The activity is 'PS2SFPD70' with the name 'S5: Prepare and Submit Deck and Sidewalk Shop Drawings (3)'. The project is 'D261458-1SU15-1'. The 'Duration' section shows: Original 30.0d, Actual 12.0d, Remaining 0.0d, and At Complete 12.0d. The 'Status' section shows: Started on 09-Apr-11 08:00 (100% Duration %), and Finished on 20-Apr-11 17:00. The 'Constraints' section shows Primary and Secondary constraints set to '< None >'. The 'Labor Units' section shows Budgeted, Actual, Remaining, and At Complete all set to 0.0d.

Relationship Tab

Examine Predecessor and Successor ties between activities by going to the Relationship tab. You can also see the Relationship Type and the Activity Status in this tab.

The screenshot shows the 'Relationships' tab in the Primavera P6.1 client. It displays two panels: 'Predecessors' and 'Successors'. Both panels show a table of activity relationships. The 'Predecessors' panel shows one entry: Activity ID PS2SFPD5C, Activity Name 'S5: NYSDOT Review (2) and Approve...', Relationship 'FS', Lag '0.0d', Driving checked, Critical unchecked, and Activity Status 'Completed'. The 'Successors' panel shows one entry: Activity ID PS2SFPD70, Activity Name 'S5: NYSDOT Review (3) and Approve De...', Relationship 'FS', Lag '0.0d', Driving checked, Critical unchecked, and Activity Status 'Completed'. At the bottom of each panel are buttons for 'Assign', 'Remove', and 'GoTo'.

Introduction to Critical Path Method Scheduling using Primavera P6.1 Client for Construction

Notebook Tab

The Notebook tab enables you to review and assign notes to an activity. The contractor may enter information in the notebook tab, by Notebook Topic. Notebook topics have been categorized by NYSDOT for specific types of information.

Steps:

1. Click **Notebook** tab.

2. In the **Notebook Topic** window, click **Add**.

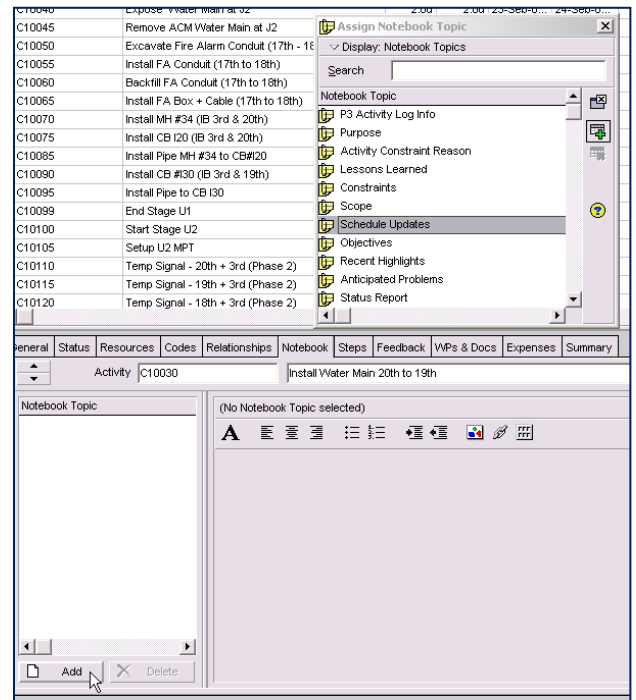

3. Select **Schedule Updates** and click the **Assign** button.

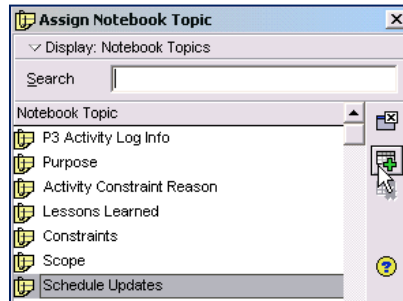

4. Go to the **Notebook** window and write a memo.

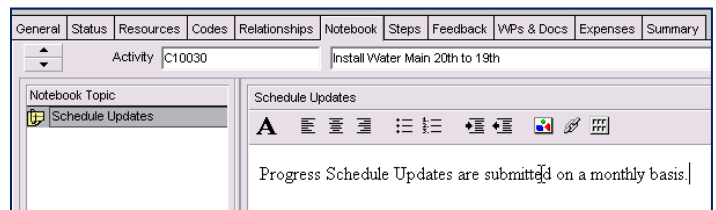

Introduction to Critical Path Method Scheduling using Primavera P6.1 Client for Construction

WPs and Docs Tab

Documents and other work products may be appended to the Activity or WBS Details using the WPs and Docs tab. This could be a useful way to centralize as well as standardize the location of project documents and narratives.

Steps:

1. Open a project.

2. On the **Directory Bar** click the **WPs and Docs** tab.

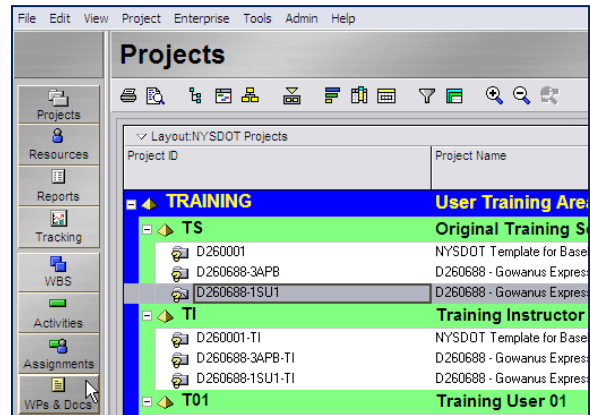

3. On **Work Products and Documents** window, click the **Add** button.

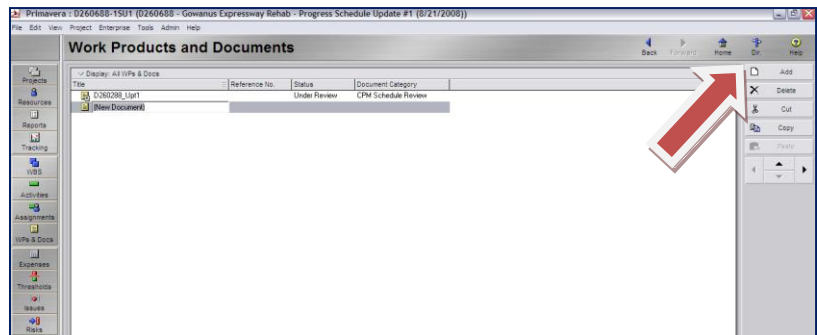

4. Provide a name for the document.

5. On the bottom layout, click the **Ellipsis** box  and plug in the location of the document.

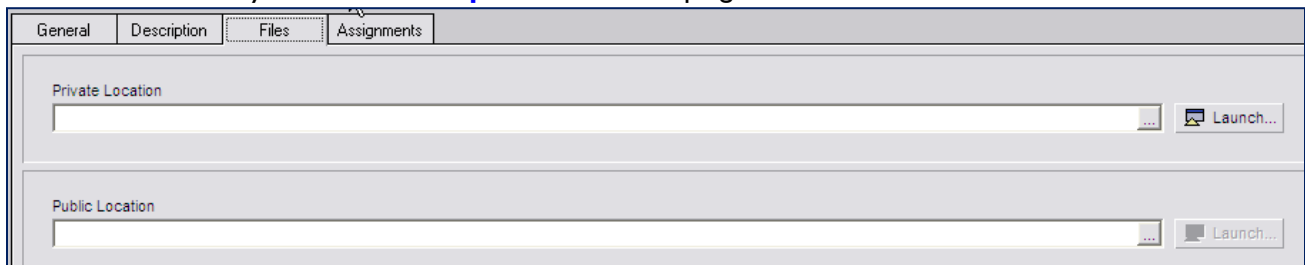

Introduction to Critical Path Method Scheduling using Primavera P6.1 Client for Construction

6. Click the **Assignments** tab and select the Activity or WBS to append document to.

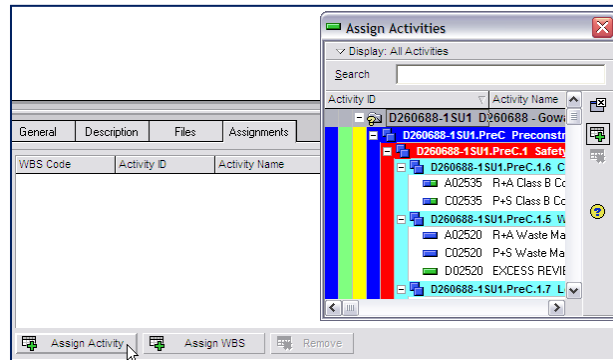

7. Click the **General** tab and plug in the details about the document.

The screenshot shows the 'General' tab of the document details form. The form contains the following fields:

Field	Value
Title	(New Document)
Version	1
Revision Date	01-Mar-10 12:00 AM
Reference No.	
Document Category	
Status	<None>
Author	
Deliverable	<input type="checkbox"/>

Introduction to Critical Path Method Scheduling using Primavera P6.1 Client for Construction

Calendar Assignments

Excerpt from Paragraph 2.d.xii (Baseline Progress Schedule @ Award):

- xii) **Calendars** - Use clearly defined calendars that account for expected seasonal weather conditions (including winter shutdown periods) and environmental permit requirements, for the planning and scheduling of activities. Do not incorporate an activity with a description of “Winter Shutdown” that requires constraints. Provide the working days per week, holidays, the number of shifts per day, and the number of hours per shift by using the Calendar modifier in the P6 software. Incorporate any seasonal restrictions to the work within calendars assigned to activities.
- Calendars related to specific resources (i.e., a specific person or piece of equipment) shall be established as Resource Calendars, with the Calendar name clearly identifying the resource.
 - All other calendars developed by a Contractor shall be established as Project Calendars, with the calendar name including the contract D# and describing the function (i.e., D260000 - Asphalt Calendar, D260000 - Concrete Calendar, D260000 - Landscape Calendar, D260000 - Painting Calendar, D260000 – Contractor’s 5 Day/8 Hour Workweek). All work activities of the Contractor shall be assigned to Project Calendars.
 - Any Global calendars used in the progress schedule shall be those established by the Department. There are only two Global Calendars developed and maintained by the Department for use by Contractor’s, they are the following:
 - **NYSDOT Milestone/Curing 365 Day / 8 hour**
 - **State Business Days, 5 Day Work Week w/State Holidays, Field**

Calendars may be created and assigned to each activity and resource. Calendar assignments are used to schedule activities and resources.

- An unlimited number of calendars can be created.

NYSDOT has developed a few predefined Global Calendars for contractors to use for certain activities on their projects.

Introduction to Critical Path Method Scheduling using Primavera P6.1 Client for Construction

Calendar Types

There are three calendar pools:

- **Global Calendar pool** – Developed by NYSDOT Admin users
 - Contains two calendars authorized by NYSDOT that can be used by all projects.
 - Available for all activities and resources.

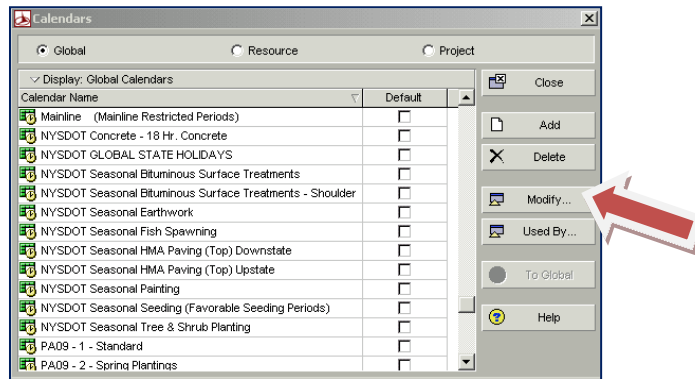

- **Resource calendar pool**
 - Contains separate calendars for each resource.
 - Available for resources
- **Project calendar pool**
 - Contains a separate pool of calendars for each project.
 - Available for the current project only.
 - Developed by the Contractor
 - Must be reviewed by NYSDOT.

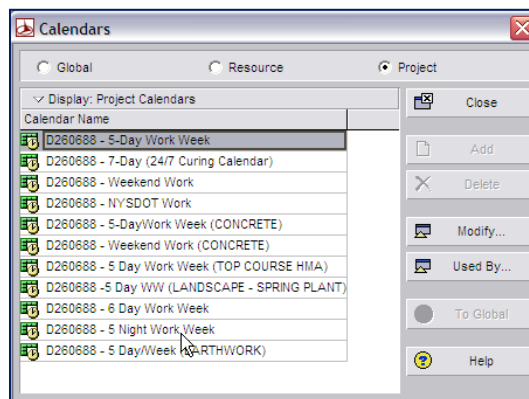

Steps:

Click **Enterprise, Calendars**. To see calendar details, click the **Modify** tab.

Introduction to Critical Path Method Scheduling using Primavera P6.1 Client for Construction

Activity Codes

Activity codes are ways to classify and categorize activities according to the needs of NYSDOT and the Contractor.

You can use activity codes to view and roll up activities in the activity table; build reports in the Report Wizard or Report Editor; organize a layout by grouping activities into specific categories; and select and summarize activities.

Excerpt from Paragraph 2.d.xv (Baseline Progress Schedule @ Award):

- xv) **Activity Codes** – The Contractor shall include a well-defined activity coding structure that allows project activities to be sorted and filtered. Activity Codes shall include, but not be limited to: Responsible Party; Stage; Area of Work; Type of Work; Subcontractor; and additionally as required by the Engineer to meet the needs of the specific contract work to facilitate the use and analysis of the schedule.
- **Activity codes can be global** (developed by NYSDOT)
 - Organize within a project or across the entire organization
 - The Department can create an unlimited number of global activity codes
- **Activity codes can be project specific** (developed by Contractor)
 - The Contractor can create up to 500 project-specific activity codes
- **Each activity code (global, EPS, and project) may contain an unlimited number of activity code values.**
- **Activity codes can be organized in a hierarchy.**

Steps:

Click [Enterprise, Activity Codes](#).

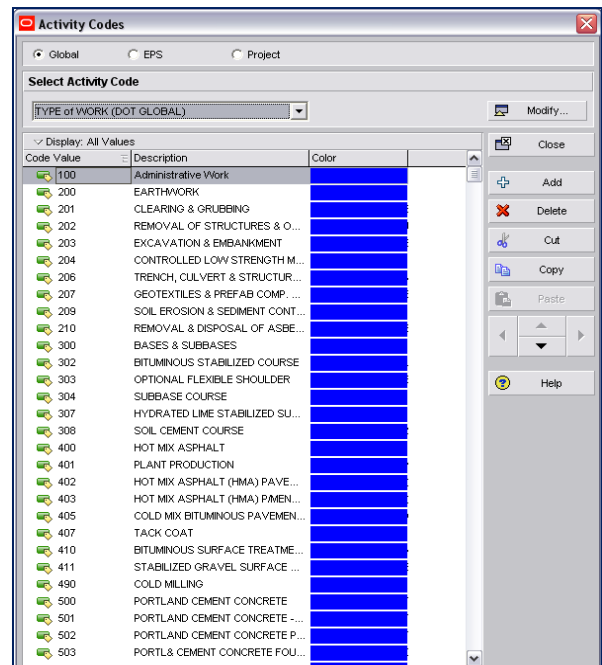

Introduction to Critical Path Method Scheduling using Primavera P6.1 Client for Construction

Lesson 4: Working with Activities

Review Questions

1. According to **Specification 2. Baseline Schedule @ Award, xiv – Activity Resources**, how many entities should own the responsibility for an activity?
2. What are the differences between a **Task Dependent** and **Resource Dependent** activities?
3. How would you check the details of a calendar using P6?
4. How can **Activity Codes** be used by the contractor to develop a report in Primavera to generate a list of all submittals they have in their Progress Schedule?
5. Why is the **Activity Relationship** a mandatory activity component?

Introduction to Critical Path Method Scheduling using Primavera P6.1 Client for Construction

Lesson 5:

Customizing Project and Activity Data Layouts

Objectives

This lesson examines the different Project layouts and Activity layouts. At the completion of this lesson, you will be able to:

- **Open and understand Project layouts**
- **Open and customize existing Activity layouts**
- **Format Project and Activity data columns**
- **Display data using Group and Sort function**
- **Understand the different options for saving a layout**
- **Use filters to customize activities layout**
- **Use Activity Codes in combination with *Filter* and *Group & Sort* functions to produce custom views and reports**

Introduction to Critical Path Method Scheduling using Primavera P6.1 Client for Construction

Data Layout

A layout is a saved customized view of schedule data information. It is a combination of all the visual elements that appear on the screen. Layouts are available in the Project, WBS, Activity and Resource windows.

Project

Projects are created within the EPS.

Project Layout

The Projects window provides option of viewing data in top/bottom layouts. The department uses a standard global layout named **“NYSDOT Projects.”**

- Choose one of the following to show on top:
 - Project Table
 - Gantt Chart
 - Chart View

The bottom layout can only display Project Details.

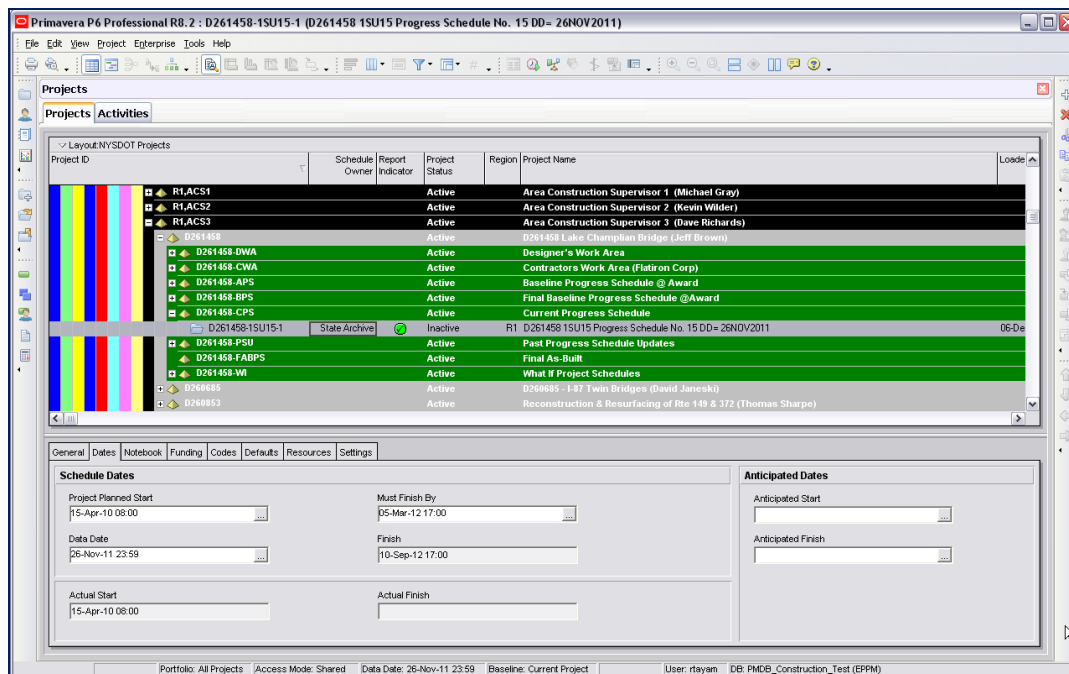

Introduction to Critical Path Method Scheduling using Primavera P6.1 Client for Construction

Activity

Activities are the fundamental work elements of a project. They are the lowest level of a WBS and, as such, are the smallest subdivision of a project. Activities represent the work that must take place in a determined amount of time.

Activity Layouts

The Activities window provides the option of viewing data in top/bottom layouts.

- Choose one of the following to show on top:
 - Activity Table
 - Gantt Chart
 - Activity Usage Spreadsheet
 - Activity Network

- Choose one of the following to show on bottom:
 - Activity Details
 - Activity Table
 - Gantt Chart
 - Activity Usage Spreadsheet
 - Resource Usage Spreadsheet
 - Activity Usage Profile
 - Resource Usage Profile
 - Trace Logic

Introduction to Critical Path Method Scheduling using Primavera P6.1 Client for Construction

Opening an Existing Layout

You can choose from a number of layouts to present activity data from different perspectives, allowing you to spend more time managing projects instead of repeatedly preparing the displays.

You can create your own activity layouts or use Global layouts provided by NYSDOT.

Steps:

1. In the **Layout Options** bar, click **Layout, Open**

If you make any modifications to the current layout, you will be prompted to save those changes. In most cases, you will choose **No**.

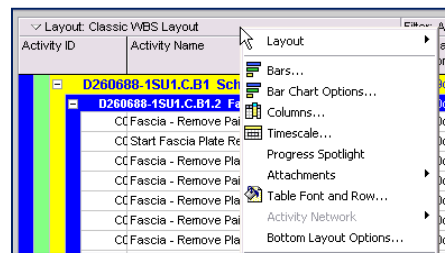

2. When prompted to save changes to the layout, click **No**.

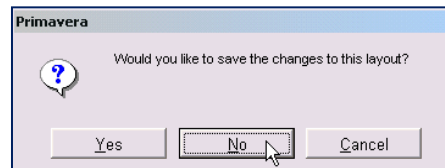

3. Select **Baseline Schedule Submission**. Click **Open**.

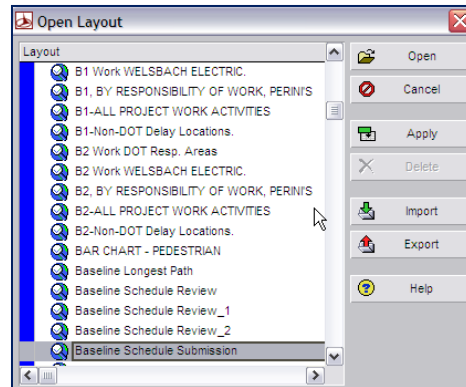

4. Next, select **Monthly Progress Schedule**. Click **Open**.

5. Examine the **Gantt Chart**. Click the **Bars** icon to check how the bar coding is defined.

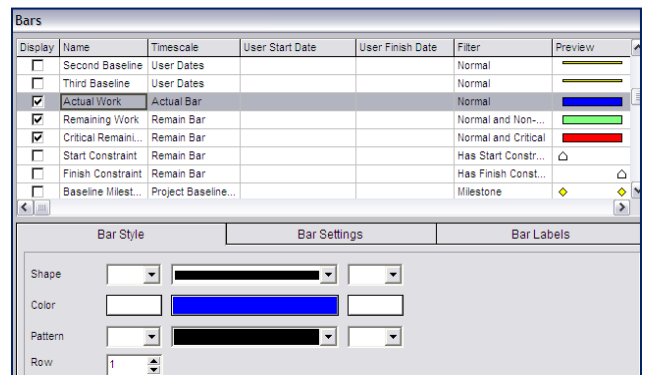

Introduction to Critical Path Method Scheduling using Primavera P6.1 Client for Construction

Gantt Chart

Excerpt from Paragraph 4.d. (Monthly Progress Schedule Submission):

xix) The following appendix in Adobe Acrobat PDF file format, formatted to fit ANSI Size D paper (610 mm x 914 mm) (24 inch x 36 inch) paper, shall be included with the narrative.

- APPENDIX 1 – A listing of all work activities as of the data date, using the Classic Schedule Layout, sorted by Early Start Date, Total Float in increasing order, showing the Activity ID, Activity Description, Original Duration, Remaining Duration, Total Float, Early Start date, Early Finish date, Start date, Finish date, and Calendar ID. The grouping of activities shall be by Area, Stage, WZTC Phase, and Type of Work. The Gantt Chart shall clearly indicate the project critical (longest) path. Graphical representations shall be shown at a suitable scale to be legible and readable.

The **Classic Schedule Layout** displays a **Gantt Chart** in the top layout, and **Activity Details** in the bottom layout.

- **Activity Table** – Displays activity data in columns.
- **Gantt Chart (known as Bar Area)** – Provides a graphical display of activity progress over the duration of the project.

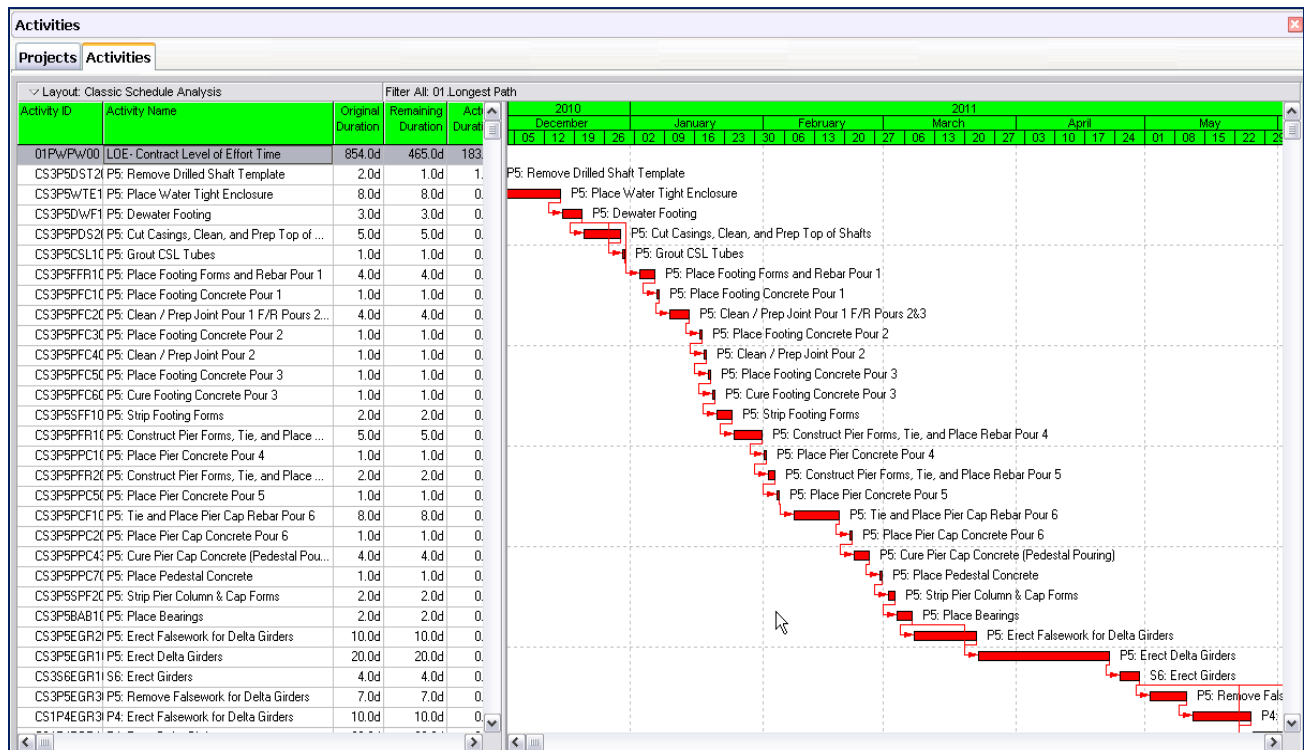

Introduction to Critical Path Method Scheduling using Primavera P6.1 Client for Construction

Activity Table

You can display the Activity Table on the screen if you want to analyze data in a tabular format.

- Enables you to see project data in spreadsheet format.
- You can modify the columns displayed in the Activity Table to meet your needs.

Steps:

In the **Layout Options** bar, click **Show on Top, Activity Table**.

The screenshot shows the 'Layout' menu in the Primavera P6.1 Client. The menu is open, and the 'Show on Top' option is selected. A sub-menu is displayed, showing the 'Activity Table' view selected. The background shows a Gantt chart with a table of activity data.

Activity	Original Duration	Remaining Duration	Actual Duration
of Effort Time	854.0d	465.0d	183.0d
Shaft Template	2.0d	1.0d	1.0d
ht Enclosure	8.0d	8.0d	0.0d
	3.0d	3.0d	0.0d
an, and Prep Top of ...	5.0d	5.0d	0.0d
s	1.0d	1.0d	0.0d
orms and Rebar Pour 1	4.0d	4.0d	0.0d
oncrete Pour 1	1.0d	1.0d	0.0d
nt Pour 1 F/R Pours 2...	4.0d	4.0d	0.0d
oncrete Pour 2	1.0d	1.0d	0.0d
nt Pour 2	1.0d	1.0d	0.0d
oncrete Pour 3	1.0d	1.0d	0.0d
oncrete Pour 3	1.0d	1.0d	0.0d
te Pours	1.0d	1.0d	0.0d

Introduction to Critical Path Method Scheduling using Primavera P6.1 Client for Construction

Customizing Columns

You can use Hint Help to view a definition for any data item in the column list.

Steps:

1. Click the **Layout Options** bar, select **Columns**.

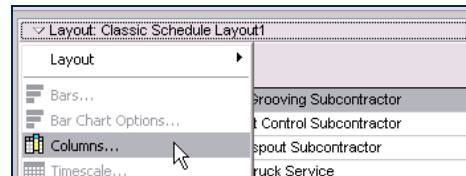

2. At **Columns** window, click the **Available Options** bar and select **Hint Help**.

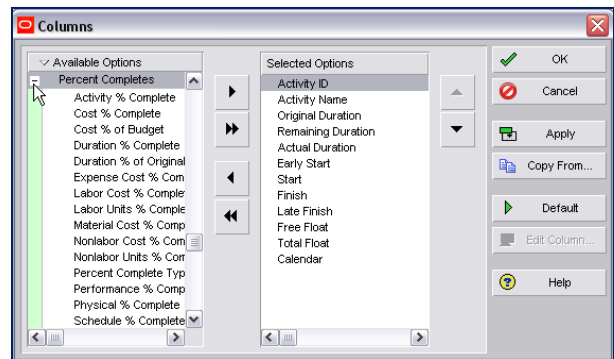

3. Inside the **Available Options** column, click the **+** sign next to **Percent Completes**.

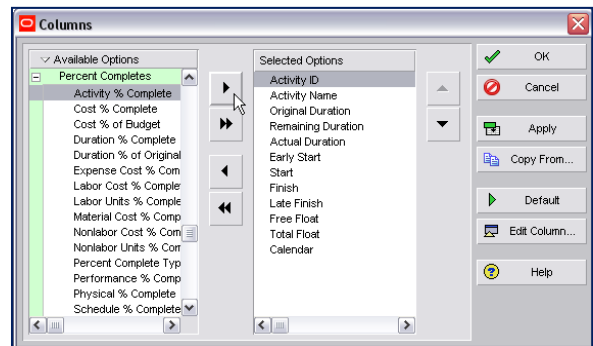

4. Highlight **Activity % Complete** and click **▶**.

5. To get the definition of the different columns, click the column titles.

6. To move **Hint Help** dialog box, click  icon.

It will turn to  icon. Drag the box to your desired location on the screen.

7. To disable **Hint Help**, click  icon.

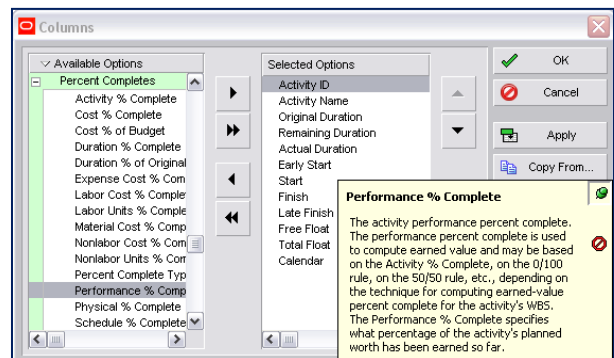

Introduction to Critical Path Method Scheduling using Primavera P6.1 Client for Construction

Displaying Activity Details

Activity Details displays detailed information for the activity highlighted in the Activity Table or Activity Network.

Steps:

In the **Layout Options** bar, click **Show on Bottom, Activity Details**.

The screenshot shows the Primavera P6.1 Client interface. The main window is titled 'Activities' and contains a table of activities. The table has the following columns: Original Duration, Remaining Duration, Actual Duration, Early Start, Start, Finish, Late Finish, Free Float, and Total Float. The activities listed include 'of Effort Time', 'Shaft Template', 'nt Enclosure', 'an, and Prep Top of ...', 's', 'rms and Rebar Pour 1', 'concrete Pour 1', 'nt Pour 1 F/R Pours 2...', 'concrete Pour 2', 'nt Pour 2', 'concrete Pour 3', 'crete Pour 3', 'ms', 'nt Pour 2', 'concrete Pour 3', and 'ms'. A context menu is open over the 'Activity Details' option, and the 'Activity Details' window is visible on the right side of the interface. The 'Activity Details' window shows a Gantt chart for the activity 'P5: Remove Drilled Shaft Template'.

Activity	Original Duration	Remaining Duration	Actual Duration	Early Start	Start	Finish	Late Finish	Free Float	Total Float
of Effort Time	854.0d	465.0d	183.0d	28-Nov-10...	29-May-10...	06-Mar-12...	05-Mar-12 17:00	0.0d	-1.0d
Shaft Template	2.0d	1.0d	1.0d	30-Nov-10...	24-Nov-10...	30-Nov-10...	23-Nov-10 17:00	0.0d	-2.0d
nt Enclosure	8.0d	8.0d	0.0d	02-Dec-10...	02-Dec-10...	15-Dec-10...	09-Dec-10 17:00	0.0d	-2.0d
an, and Prep Top of ...	3.0d	3.0d	0.0d	16-Dec-10...	16-Dec-10...	20-Dec-10...	16-Dec-10 17:00	0.0d	-2.0d
s	5.0d	5.0d	0.0d	21-Dec-10...	21-Dec-10...	29-Dec-10...	27-Dec-10 17:00	0.0d	-2.0d
rms and Rebar Pour 1	1.0d	1.0d	0.0d	30-Dec-10...	30-Dec-10...	30-Dec-10...	28-Dec-10 17:00	0.0d	-2.0d
concrete Pour 1	4.0d	4.0d	0.0d	03-Jan-11...	03-Jan-11...	06-Jan-11...	04-Jan-11 17:00	0.0d	-2.0d
nt Pour 1 F/R Pours 2...	1.0d	1.0d	0.0d	07-Jan-11...	07-Jan-11...	07-Jan-11...	05-Jan-11 17:00	0.0d	-2.0d
concrete Pour 2	4.0d	4.0d	0.0d	10-Jan-11...	10-Jan-11...	14-Jan-11...	12-Jan-11 17:00	0.0d	-2.0d
nt Pour 2	1.0d	1.0d	0.0d	17-Jan-11...	17-Jan-11...	17-Jan-11...	13-Jan-11 17:00	0.0d	-2.0d
concrete Pour 3	1.0d	1.0d	0.0d	18-Jan-11...	18-Jan-11...	18-Jan-11...	14-Jan-11 17:00	0.0d	-2.0d
crete Pour 3	1.0d	1.0d	0.0d	19-Jan-11...	19-Jan-11...	19-Jan-11...	17-Jan-11 17:00	0.0d	-2.0d
ms	1.0d	1.0d	0.0d	20-Jan-11...	20-Jan-11...	20-Jan-11...	18-Jan-11 17:00	0.0d	-2.0d
ms	2.0d	2.0d	0.0d	21-Jan-11...	21-Jan-11...	24-Jan-11...	21-Jan-11 17:00	0.0d	-1.0d
nt Pour 2	5.0d	0.0d	0.0d	25-Jan-11...	25-Jan-11...	31-Jan-11...	28-Jan-11 17:00	0.0d	-1.0d
concrete Pour 3	1.0d	0.0d	0.0d	01-Feb-11...	01-Feb-11...	01-Feb-11...	31-Jan-11 17:00	0.0d	-1.0d
ms	2.0d	0.0d	0.0d	02-Feb-11...	02-Feb-11...	03-Feb-11...	02-Feb-11 17:00	0.0d	-1.0d
ms	1.0d	0.0d	0.0d	04-Feb-11...	04-Feb-11...	04-Feb-11...	03-Feb-11 17:00	0.0d	-1.0d

Introduction to Critical Path Method Scheduling using Primavera P6.1 Client for Construction

Selecting Detail Tabs

The tabs displayed in Activity Details are customizable.

Steps:

1. In the **Layout Options** bar, click **Bottom Layout Options**.

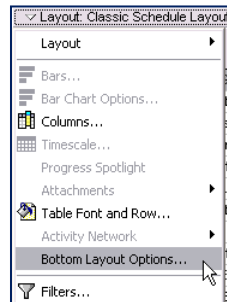

2. In the **Available Tabs**, select **Notebook**.

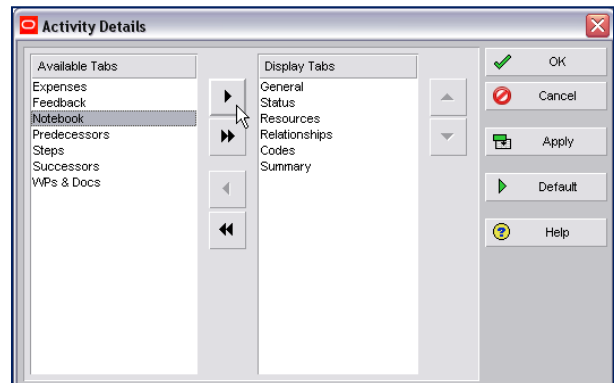

3. To move the selected data item into the **Display Tabs** column, double-click or click .

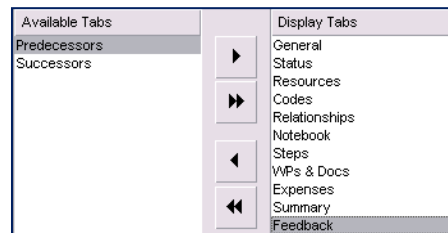

4. To move the columns to left or right, highlight and

press the .

5. Click **OK**.

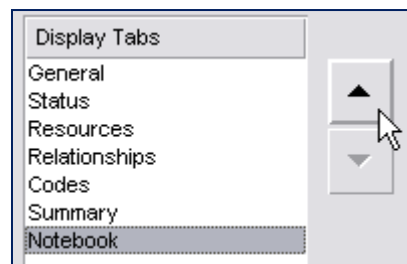

Introduction to Critical Path Method Scheduling using Primavera P6.1 Client for Construction

Grouping Data

Grouping is a flexible way to organize data into categories that share a common attribute. You can group data to customize layouts, which can be used for reporting purposes.

You can quickly view subtotal data in the group title bands, view summary bars in the Gantt Chart, and summarize data for reporting purposes.

- Grouping is available in all the windows and most dialog boxes.
 - Each window or dialog box has its own grouping options.
 - Some windows have customized/pre-defined groups.
- Activities can be grouped by hierarchical fields such as WBS, activity codes, and project codes.
- Activities can be grouped by data fields such as dates, costs, total float, and other numeric data.

Steps:

1. Open your project and go to the Activities window.
2. In the Layout Options Bar, right-click and select **Group and Sort**. Or click from the Menu bar.

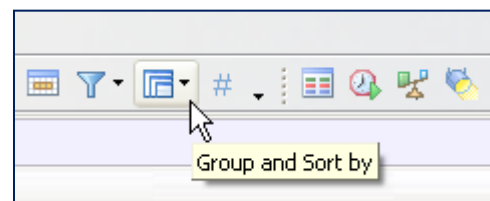
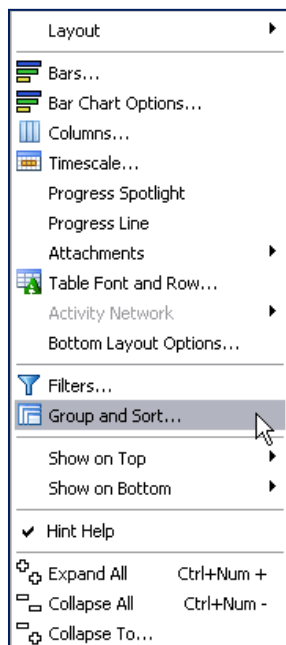

Introduction to Critical Path Method Scheduling using Primavera P6.1 Client for Construction

Group and Sort Dialog Box

The Group and Sort dialog box is used to set up how you want to organize activities on screen.

- **Show Grand Totals** – Mark to display a grand total row at the top of the layout.
- **Show Summaries Only** – Mark to hide the activities within each group title band.
- **Group By** – Lists data items used to group the current display.
- **To Level** – Indicates the number of levels to display when grouping by hierarchical data item.
- **Group Interval** – Indicates the interval by which you want to group the selected data item.
- **Font & Color** – Displays the font/color for each group title band.
- **Show Title** – Mark to display the name of the field that the layout is grouped by; the value will also be displayed.
- **Hide if Empty** – Mark to hide the group title bands that do not contain activities.

Group By	Indent	To Level	Group Interval	Page Break	Font & Color
wBS level 1	<input checked="" type="checkbox"/>	4		<input type="checkbox"/>	12 Arial
wBS level 2				<input type="checkbox"/>	11 Arial
wBS level 3				<input type="checkbox"/>	9 Arial
wBS level 4				<input type="checkbox"/>	8 Arial
					8 Arial

Introduction to Critical Path Method Scheduling using Primavera P6.1 Client for Construction

Grouping by Location, SubLocation & Type of Work

Steps:

1. Open the **Lake Champlain Bridge** project.
2. Click the **Layout Bar** and select **Monthly Progress Schedule Submission**.
3. On the Menu bar, click the **Group & Sort** icon .
4. On the first row of the **Group By** column, select **LC- Location**. Uncheck the checkmark under the **Indent** column. On the second row, select **LC-Sub Location**. On the third row, select **Type of WORK (DOT GLOBAL)**.

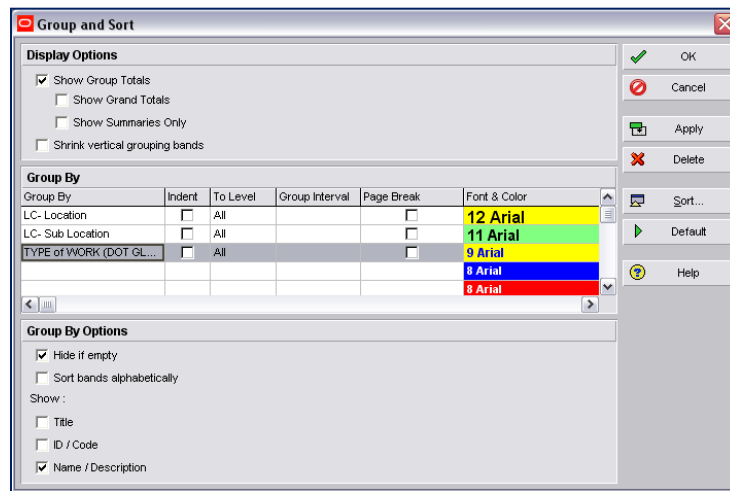

5. Click **OK**.

Activity ID	Activity Name	Original Duration	Remaining Duration	Early Start	Start	Finish	Late Finish	Total Float	Free Float	Calendar
Section 1 NY to Pier 4										
New York Approach										
Administrative Work										
CS1NAMOB50	NA: Mobilize Electrical Sub	4.0d	0.0d	27-Nov-10...	21-Jun-10...	22-Nov-10...	01-Jul-11 0...		0.0d	D261458 - Basic 724
PS1NAMOB10	NA: Mobilize Roadway Demo Sub	4.0d	0.0d	27-Nov-10...	21-Jun-10...	25-Jun-10 1...	17-Jun-11 ...			D261458 - Basic 724
PS1NAMOB20	NA: Mobilize Roadway Earthwork Sub	4.0d	0.0d	27-Nov-10...	21-Jun-10...	25-Jun-10 1...	17-Jun-11 ...			D261458 - Basic 724
CS1NAMOB40	NA: Mobilize Roadway Drainage Sub	4.0d	0.0d	27-Nov-10...	30-Jun-10...	01-Jul-10 1...	17-Jun-11 ...			D261458 - Basic 724
CS1NAMOB60	NA: Coordinate with Utility Companies	15.0d	0.0d	27-Nov-10...	05-Jul-10 0...	19-Jul-10 1...	17-Jun-11 ...			D261458 - Basic 724
PS1NAMOB30	NA: Mobilize Roadway Retaining Wall Sub	4.0d	0.0d	27-Nov-10...	09-Aug-10...	13-Aug-10...	17-Jun-11 ...			D261458 - Basic 724
PS1NATWL10	NA: Fabricate and Deliver NY T-Wall	4.0d	0.0d	27-Nov-10...	10-Sep-10...	22-Nov-10...	01-Jul-11 0...			D261458 - Basic 724
EARTHWORK										
CS1NAGS10	NA: Place Granite Stone Curb	10.0d	10.0d	21-Jun-11 0...	21-Jun-11...	05-Jul-11 1...	06-Sep-11...	44.0d	0.0d	D261458 - Basic 510 w/ Holidays
CS1NABFL10	NA: Back Fill to Sidewalks	4.0d	4.0d	15-Aug-11...	15-Aug-11...	19-Aug-11...	24-Oct-11...	43.0d	0.0d	D261458 - Earthwork
CS1NATPS10	NA: Place Top Soil	8.0d	8.0d	22-Aug-11...	22-Aug-11...	31-Aug-11...	07-Nov-11...	43.0d	0.0d	D261458 - Earthwork
CS1NALDS10	NA: Seed and Landscape	5.0d	5.0d	01-Sep-11...	01-Sep-11...	08-Sep-11...	14-Nov-11...	43.0d	43.0d	D261458 - Earthwork
CLEARING & GRUBBING										
CS1NACAG10	NA: Clear and Grub	4.0d	0.0d	27-Nov-10...	28-Jun-10...	01-Jul-10 1...	17-Jun-11 ...			D261458 - Earthwork
EXCAVATION & EMBANKMENT										
CS1NAEX10	NA: Excavate to Grade	4.0d	0.0d	27-Nov-10...	29-Jul-10 0...	19-Aug-10...	17-Jun-11 ...		0.0d	D261458 - Earthwork
SOIL EROSION & SEDIMENT CONTROL										
CS1NASWP10	NA: Place Erosion Control and SWP3 Measures	5.0d	0.0d	27-Nov-10...	28-Jun-10...	22-Jul-10 0...	02-May-11...		0.0d	D261458 - Earthwork
BASES & SUBBASES										
CS1NAGDF10	NA: Place Expanded Polystyrene Fill	4.0d	4.0d	18-Apr-11 0...	18-Apr-11...	21-Apr-11 1...	26-Aug-11...	84.0d	1.0d	D261458 - Earthwork
CS1NAF9B10	NA: Place 37.5 F3 Base Course	6.0d	6.0d	06-Jul-11 0...	06-Jul-11 0...	14-Jul-11 1...	14-Sep-11...	42.0d	0.0d	D261458 - Asphalt Placement
SUBBASE COURSE										
CS1NASBC10	NA: Place Sub Base Course Type 2	6.0d	6.0d	25-Apr-11 0...	25-Apr-11...	02-May-11...	06-Sep-11...	85.0d	43.0d	D261458 - Asphalt Placement
CS1NASBC20	NA: Place Sub Base Type 2 for Sidewalks	4.0d	4.0d	01-Jun-11 0...	01-Jun-11...	06-Jun-11 1...	08-Aug-11...	43.0d	0.0d	D261458 - Asphalt Placement
HOT MIX ASPHALT										
CS1NATP40	NA: Place Asphalt Sidewalks, Driveways, and Bike ...	10.0d	10.0d	06-Jul-11 0...	06-Jul-11 0...	20-Jul-11 1...	26-Sep-11...	45.0d	1.0d	D261458 - Asphalt Placement
CS1NATP10	NA: Place Tack Coat 1	2.0d	2.0d	15-Jul-11 0...	15-Jul-11 0...	18-Jul-11 1...	16-Sep-11...	42.0d	0.0d	D261458 - Asphalt Placement

Introduction to Critical Path Method Scheduling using Primavera P6.1 Client for Construction

Filtering Activities

A filter is a set of instructions that determines which activities should display on screen.

Filters enable you to create customized layouts by limiting the number of activities displayed – helping you to focus on critical activities, for example.

- A set of pre-defined filters is provided, as is the ability to create user defined filters of your own.
- Filters divided into the following groupings:
 - ***Default***
 - Available to all users
 - 15 pre-defined filters
 - Cannot be deleted or modified
 - ***Global***
 - Available to all users
 - ***User Defined***
 - Available to current users for all projects to which they have access
- One or more filters may be applied to a layout at a time.
- Multiple criteria for selection may be used within a single filter.
- Filter specifications can be saved and reapplied.
- Filters can be saved as part of a layout.

Introduction to Critical Path Method Scheduling using Primavera P6.1 Client for Construction

Filter Dialog Box

- **All Activities** – Click box to show all activities in the current layout.
- **Show activities that match** – When more than one filter is marked, you must define the join by selecting one of the following options:
 - All Selected Filters – Click to include the activities that meet the criteria of each selected filter.
 - Any Selected Filter – Click to include the activities that meet the criteria of a t least one of the selected filters.
- **Replace Activities Shown in Current Layout** – Displays only the activities that meet the criteria of each selected filter.
- **Highlight activities in current layout which match criteria** – Highlights only the activities in the current layout that meet the criteria of each selected filter.

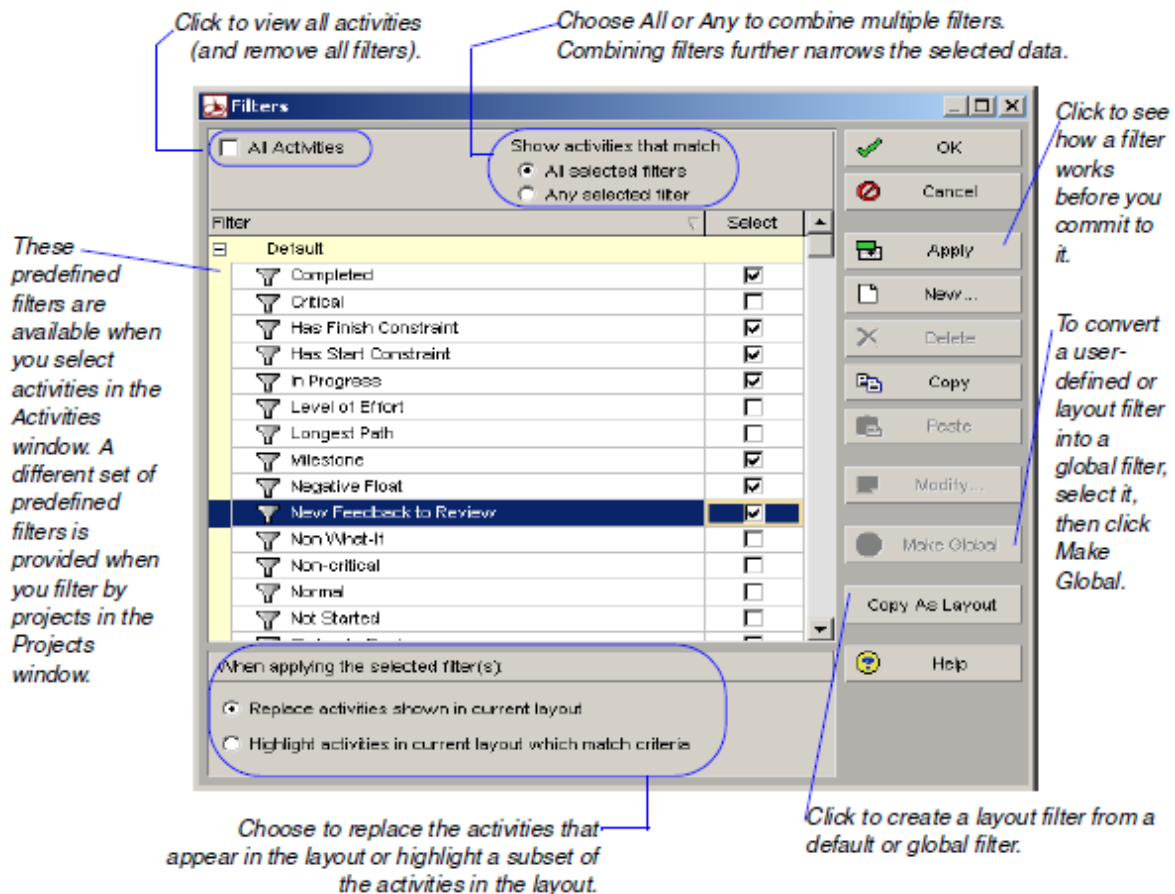

Steps:

In the **Layout Options** bar, click **Filters**.

Introduction to Critical Path Method Scheduling using Primavera P6.1 Client for Construction

Using Filters to Customize Activity Layout

Steps:

1. Open the **Gowanus Rehab job Update #1**. Go to **Activities**. Click the **Layout Bar** and select **Classic Schedule Analysis**.

2. From the Toolbar, click the **Filters** icon. Click **Completed**, **Critical** and **Not Started** filters. Leave the selection to **Any Selected Filter**.

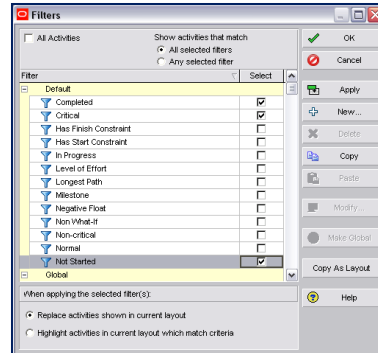

3. Go back to Filters and click **All Selected Filter**.

Activity ID	Activity Name	Original Duration	Remaining Duration	Actual Duration	Start	Finish
C07105	P+S Deck Shielding Plan	10.0d	0.0d	12.0d	14-Jul-08 12:00 AM A	30-Jul-08 12:00 A...
P07105	P+D Deck Shielding M+E	10.0d	10.0d	0.0d	12-Aug-08 04:00 PM	26-Aug-08 04:00 PM
D260688-1SU1.Prec.C.3.2	SIP Form Drawings	110.0d	110.0d	0.0d	01-Aug-08 00:00 AM	02-Sep-08 00:00 PM
C07120	P+S Precast Slab Unit Drawings	30.0d	30.0d	0.0d	01-Aug-08 08:00 AM	15-Sep-08 05:00 PM
A07120	R+A Precast Slab Unit Drawings	10.0d	10.0d	0.0d	15-Sep-08 08:00 AM	29-Sep-08 04:00 PM
P07120	P+D Precast Slabs	60.0d	60.0d	0.0d	29-Sep-08 04:00 PM	02-Jan-09 03:00 PM
D260688-1SU1.Prec.3	Utility Cuts	42.0d	42.0d	42.0d	02-Jun-08 12:00 A...	11-Nov-08 04:00 PM
D260688-1SU1.Prec.3.1	ITS	72.0d	72.0d	41.0d	02-Jun-08 12:00 A...	11-Nov-08 04:00 PM
D260688-1SU1.Prec.3.1.1	Fiber Cuts	40.0d	20.0d	35.0d	02-Jun-08 12:00 A...	15-Sep-08 05:00 PM
A04300	P+S Fiber Cable Cuts	20.0d	0.0d	11.0d	02-Jun-08 12:00 A...	17-Jun-08 12:00 A...
P04300	P+D Fiber Cable	30.0d	30.0d	0.0d	01-Aug-08 08:00 AM	15-Sep-08 05:00 PM
D260688-1SU1.Prec.3.1.2	Meter Cabinet Cuts	72.0d	72.0d	0.0d	01-Aug-08 08:00 AM	11-Nov-08 04:00 PM
A04320	P+S ITS Meter Cabinet Cuts	20.0d	20.0d	0.0d	01-Aug-08 08:00 AM	29-Aug-08 05:00 PM
P04320	P+D ITS Meter Cabinets	30.0d	30.0d	0.0d	29-Aug-08 08:00 AM	26-Sep-08 04:00 PM
D260688-1SU1.Prec.3.1.2	Type A Cabinet Cuts	49.0d	33.0d	14.0d	05-Jul-08 12:00 AM A	09-Oct-08 04:00 PM
C04310	P+S Type A Cabinet Cuts	20.0d	0.0d	14.0d	09-Jul-08 12:00 AM A	29-Jul-08 12:00 A...
P04310	P+D Type A Cabinets	30.0d	30.0d	0.0d	25-Aug-08 04:00 PM	09-Oct-08 04:00 PM

Activity ID	Activity Name	Original Duration	Remaining Duration	Actual Duration
D260688-1SU1	D260688 - Gowanus Expressway Rehab...	0.0d	0.0d	0.0d
D260688-1SU1.Prec	Preconstruction Activities	0.0d	0.0d	0.0d
D260688-1SU1.Prec.1	Safety Plans	0.0d	0.0d	0.0d
D260688-1SU1.Prec.1.6	Class B Containment Plan	0.0d	0.0d	0.0d
D260688-1SU1.Prec.1.5	Waste Management Plan	0.0d	0.0d	0.0d
D260688-1SU1.Prec.1.7	Lead Exposure Plan	0.0d	0.0d	0.0d
D260688-1SU1.Prec.1.3	Absorb 360 Submission	0.0d	0.0d	0.0d
D260688-1SU1.Prec.1.2	Lighting Plan	0.0d	0.0d	0.0d
D260688-1SU1.Prec.1.8	Asbestos Removal Plan	0.0d	0.0d	0.0d
D260688-1SU1.Prec.1.4	Rodent Control Plan	0.0d	0.0d	0.0d
D260688-1SU1.Prec.5	Deck Submissions	0.0d	0.0d	0.0d
D260688-1SU1.Prec.5.7	Joint Sealing Materials	0.0d	0.0d	0.0d
D260688-1SU1.Prec.5.8	Downspout Drawings	0.0d	0.0d	0.0d
D260688-1SU1.Prec.5.10	Scupper Shop Drawings	0.0d	0.0d	0.0d
D260688-1SU1.Prec.5.1	Open Steel Grid Drawings	0.0d	0.0d	0.0d
D260688-1SU1.Prec.5.2	Precast Slab Drawings	0.0d	0.0d	0.0d
D260688-1SU1.Prec.5.4	Deck Demolition Plans	0.0d	0.0d	0.0d
D260688-1SU1.Prec.5.6	Armorless Joint Materials	0.0d	0.0d	0.0d
D260688-1SU1.Prec.5.9	Precast Barrier Drawings	0.0d	0.0d	0.0d
D260688-1SU1.Prec.5.5	Deck Shielding Plans	0.0d	0.0d	0.0d
D260688-1SU1.Prec.5.3	SIP Form Drawings	0.0d	0.0d	0.0d

4. To find out how filters are defined, click the **Help** button in the **Filters** window. Type **Default Filter Criteria** and click the **List Topics** button.

Contents | Index | Search | Favorites

Type in the keyword to find:

[List Topics](#)

Select Topic to display:

- Customize Timesheet Approval
- Default filter criteria
- Define the Activity Usage Profile

[Display](#)

Default filter criteria

The following table lists the criteria used for the predefined activity filters.

Filter Name	Display all rows	Parameter	Is	Value
Completed	Where	Activity Status	Equals	Completed
Critical	Where	Critical	Equals	Yes
Has Finish Constraint	Where	Primary Constraint	Equals	Finish On
	Or	Primary Constraint	Equals	Finish On or Before
	Or	Primary Constraint	Equals	Finish On or After
	Or	Primary Constraint	Equals	Mandatory Finish

Introduction to Critical Path Method Scheduling using Primavera P6.1 Client for Construction

Exercise: Creating a Lookahead Filter

1. Follow the instructions specified below and create a **Lookahead Filter** using the **Gowanus Expressway Rehab Progress Update #1** project.

Create a lookahead filter

When defining **filters**, you can select data based on their relationship to the project start date, finish date, or current date, rather than specific calendar dates. This prevents you from having to update the **filter** each time you update the project.

To create a six-week lookahead filter

1. Choose Project, Activities, then choose View, **Filters**.
2. Click New.
3. Type a **filter** name, such as Six-Week Lookahead.
4. Click the Parameter, Is, and Value fields, then specify the **filter criteria**.

Filter Name	Parameter	Is	Value
[All of the following]			
Where	Start	>	CD
And	Start	<=	CD+6w
And	Activity % Complete	is not equal to	100%

5. Click Add to enter additional levels of **criteria**.
6. Click OK to save **filter criteria**.
7. Mark the checkbox in the Select column next to the newly created **filter**, then click OK.
8. Clear the checkboxes in the Select column next to all other **filters**.

Create a lookahead filter

When defining **filters**, you can select data based on their relationship to the project start date, finish date, or current date, rather than specific calendar dates. This prevents you from having to update the **filter** each time you update the project.

To create a six-week lookahead filter

1. Choose Project, Activities, then choose View, **Filters**.
2. Click New.
3. Type a **filter** name, such as Six-Week Lookahead.
4. Click the Parameter, Is, and Value fields, then specify the **filter criteria**.

Filter Name	Parameter	Is	Value
[All of the following]			
Where	Start	>	CD
And	Start	<=	CD+6w
And	Activity % Complete	is not equal to	100%

5. Click Add to enter additional levels of **criteria**.
6. Click OK to save **filter criteria**.
7. Mark the checkbox in the Select column next to the newly created **filter**, then click OK.
8. Clear the checkboxes in the Select column next to all other **filters**.

2. Apply the filter once done. Make notes of what results it yields.
3. Modify the filter's Value setting from **CD** to **DD**. Apply and make notes of what results it yields.

Introduction to Critical Path Method Scheduling using Primavera P6.1 Client for Construction

Saving Layouts

Layouts can be saved and shared with other users to facilitate project communication.

- **Layout, Save** – Saves changes to the existing layout.
- **Layout, Save As** – Prompts you to save the layout with a new name.
 - *Current User* – Only the user creating the layout will have access to it.
 - *All Users* – All licensed users will have access to the layout (Global). Only certain NYSDOT staff will have this capability to help maintain standards.
 - *Another User* – A specified user will have access to the layout. Note, however, that the current user will not have access to the layout. Only certain NYSDOT staff will have this capability to help maintain standards.
 - *Project* – Users who have access to the project will have access to the layout.

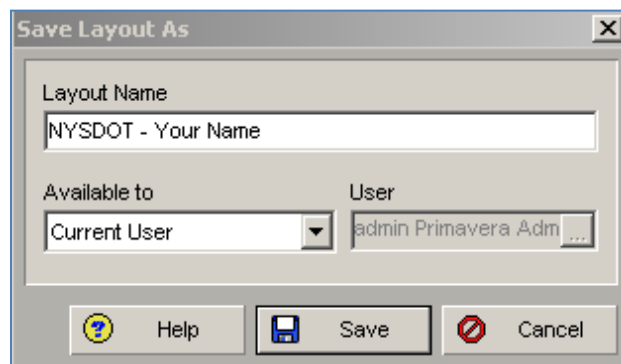

Steps:

1. In the Layout Options bar, click **Layout, Save As**.
2. Type a Layout Name **<NYSDOT – Your Name>**.
3. Verify **Current User** is selected in the *Available to* field.
4. Click **Save**.

Introduction to Critical Path Method Scheduling using Primavera P6.1 Client for Construction

Lesson 5: Customizing Project and Activity Data Layouts

Review Questions

1. **Specification 4. Monthly Progress Schedule Submission, d**, requires the submittal of the project schedule's **Gantt Chart**. Why?
2. How do you change the **Activity Layout** screen?
3. You want to change the data columns being displayed in your layout, what function will you use?
4. You just created a new layout and want to save it so that everyone who has access to the project will be able to use it. What do you do?
5. In using the Filters tool, when do you use the **All Selected Filters** option? When do you use the option **Any Selected Filter**?

Introduction to Critical Path Method Scheduling using Primavera P6.1 Client for Construction

Lesson 6:

Analyzing Relationships

Objectives

In this lesson, you will examine the different types of relationship ties between activities. At the completion of this lesson, you will be able to:

- **Explain activities relationship types**
- **Know when to use certain relationship types**
- **Identify valid and invalid logic in the relationship**
- **Understand the differences and applications of Mandatory Logic and Discretionary Logic**
- **View activity relationships**

Introduction to Critical Path Method Scheduling using Primavera P6.1 Client for Construction

Relationship Logic

As part of your schedule review, you will scrutinize how the contractor has developed the schedule logic between activities. You will determine if the relationships between activities are valid, if relationships are missing, and if the relationship type is also valid. Primavera allows the network logic to be developed precisely the way the work will actually be done.

Network Logic Diagram

A network logic diagram is a logical representation of all the activities in a project showing their dependency relationships.

Precedence Diagramming Method (PDM)

Precedence Diagramming Method (PDM) is a technique for creating network logic diagrams.

A box or rectangle represents an activity.

- Lines with arrows connect the boxes and represent the logical relationships between the activities.
 - **Predecessor** – Controls the start or finish of another activity.
 - **Successor** – Depends on the start or finish of another activity.
- Start with either the first activity in the network and enter each successor, or start with the last activity in the network and enter each predecessor.

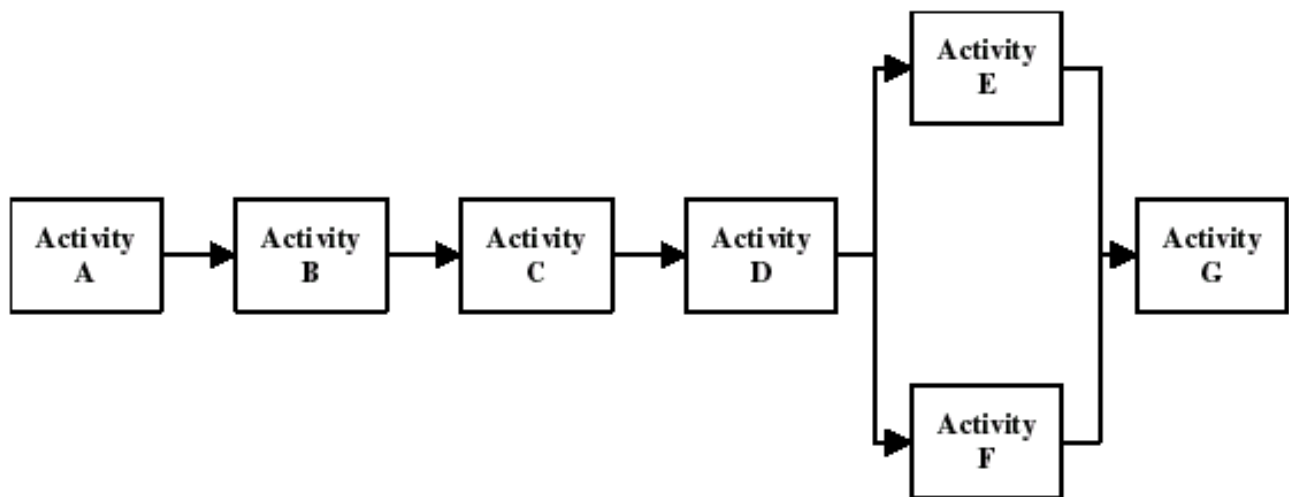

Introduction to Critical Path Method Scheduling using Primavera P6.1 Client for Construction

Relationship Types

Excerpt from Specification D. Progress Schedule, 1. General, Paragraph 4:

The Contractor will be the sole entity allowed to physically modify the following data within the progress schedule: activity IDs; activity descriptions; activity durations; relationships between activities; successors and predecessors, actual start and actual finish dates of activities; planned start and planned finish dates of activities; and activity resources (with the exception that activities assigned resources labeled to reflect Department personnel may be changed to reflect specific individuals, or job roles, within the Department).

Excerpt from Specification 4. Monthly Progress Schedule Submission, d, xiii: Paragraph 4:

- xiii) List all changes in relationships between activities included in this Progress Schedule submission, and the reason(s) for and the impact(s) of such changes.

There are four types of relationships. In the following diagrams, activity A represents the predecessor and activity B represents the successor.

Finish to Start (FS) – When A finishes, then B can start.

(Default relationship type in Primavera)

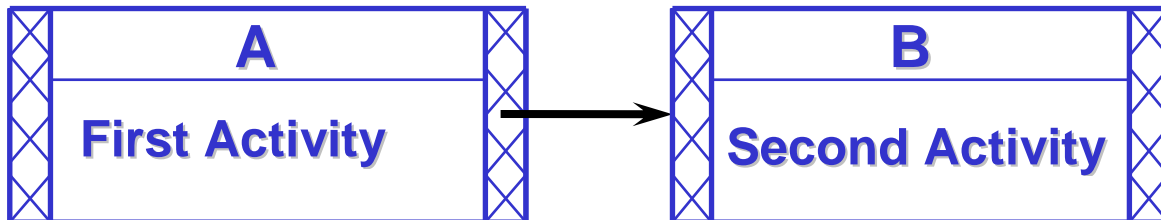

Start to Start (SS) – When A starts, B can start.

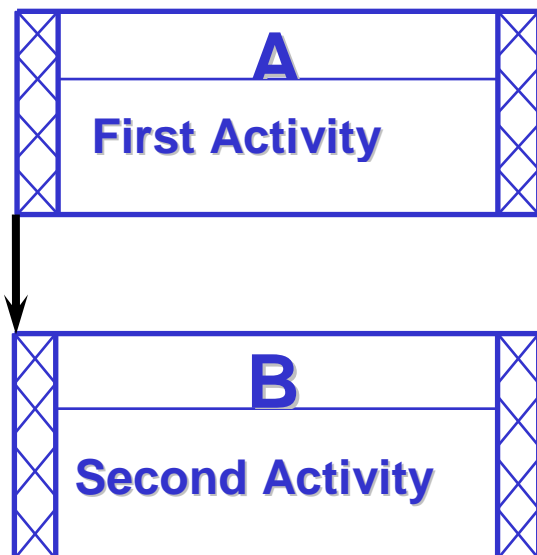

Introduction to Critical Path Method Scheduling using Primavera P6.1 Client for Construction

Finish to Finish (FF) – When A finishes, B can finish

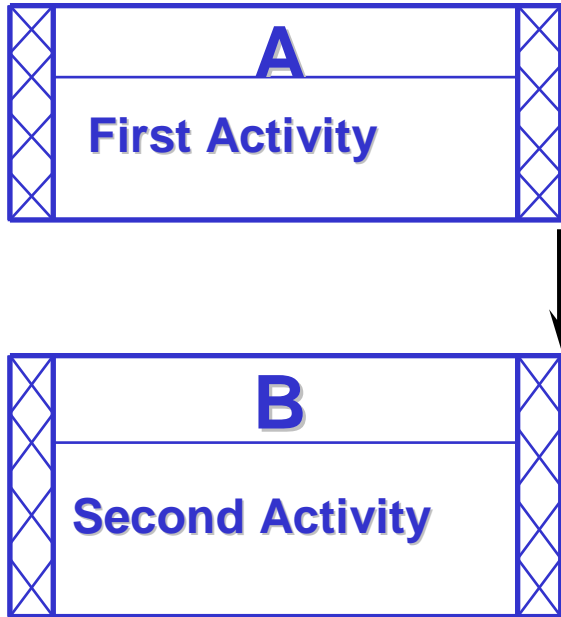

Start to Finish – When A starts, B can finish

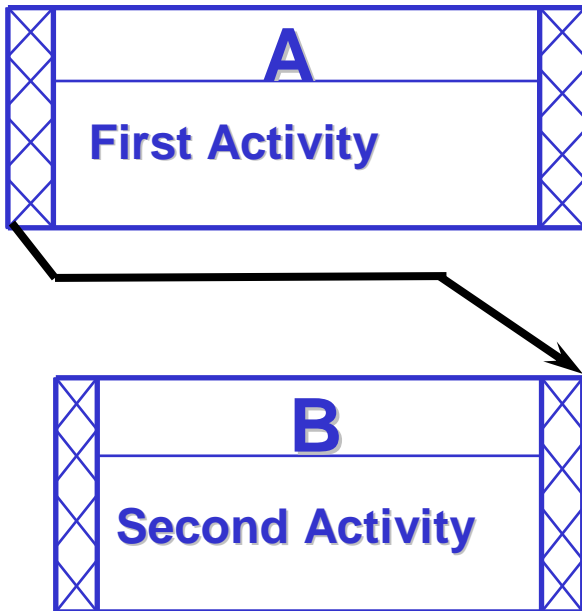

Introduction to Critical Path Method Scheduling using Primavera P6.1 Client for Construction

Relationships with Lag

Excerpt from Specification 2. Baseline Progress Schedule @ Award, viii:

viii) **Activity Relationships** - Clearly assign predecessors and successors relationships to each activity, and assign appropriate logic ties between activities (Finish to Start, Start to Start, Finish to Finish, etc). Do not have any open ended activities, with the exception of the first activity and last activity in the schedule. An activity may only appear once as a predecessor or successor to another specific activity, but may be assigned as a predecessor or successor to many different activities. **Do not include inappropriate logic ties with Milestone activities (i.e. – a finish milestone activity, and a predecessor assigned with a Finish to Start logic tie; or a start milestone, and a successor assigned with a Finish to Start logic tie). Lag time may not exceed 10 days.** The Contractor shall not use negative Lag times.

Lag specifies an offset or delay between an activity and its successor. It can be added to any type of relationship and can be positive or a negative value. For NYSDOT contracts, all lags must be positive.

Lag is scheduled based on the calendar selected in the General tab in the Schedule Options dialog box.

Examples of relationships with lag:

Finish to Start with Lag

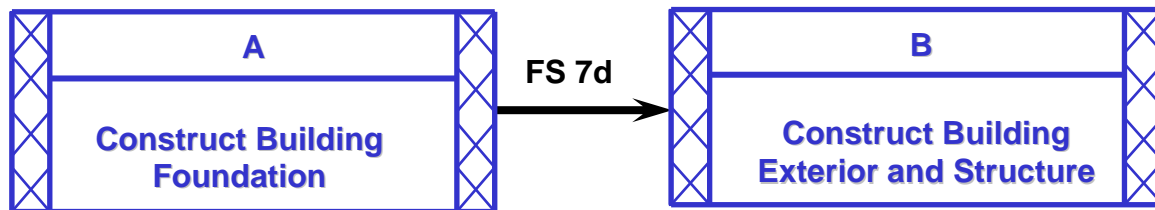

Construct Building Foundation activity must be finished for seven days before the *Construct Building Exterior and Structure* activity can start.

Note: In the Activity view, you cannot filter on Lags. However, you can use a report to “filter” on Activity lags. Two reports *Lag (Negative) Activity Relationships* and *Lag (Positive) Activity Relationships* have been created for your use in monitoring lags in your project.

Introduction to Critical Path Method Scheduling using Primavera P6.1 Client for Construction

Start to Start with Lag

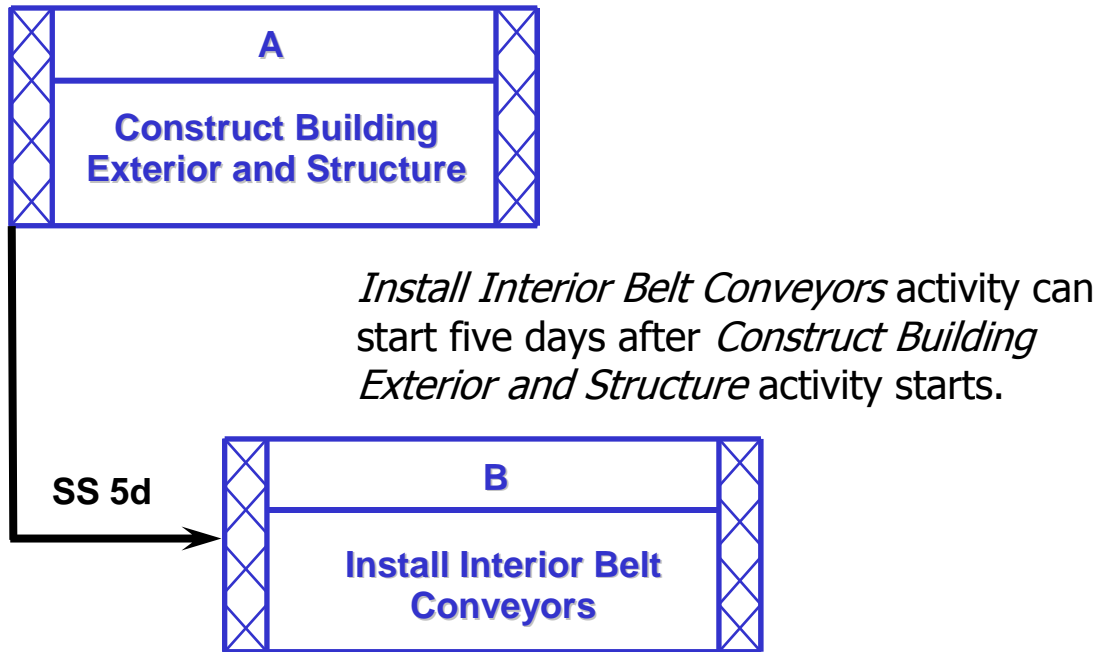

Introduction to Critical Path Method Scheduling using Primavera P6.1 Client for Construction

Viewing Relationships in Gantt Chart

You can view/modify relationships in the Activity Table and Gantt Chart.

1. **Activity Table** (left panel) – Displays the Predecessors and Successors columns.
2. **Gantt Chart** (right panel) – Click the Relationship Lines icon  on the Toolbar to toggle relationship lines on and off.

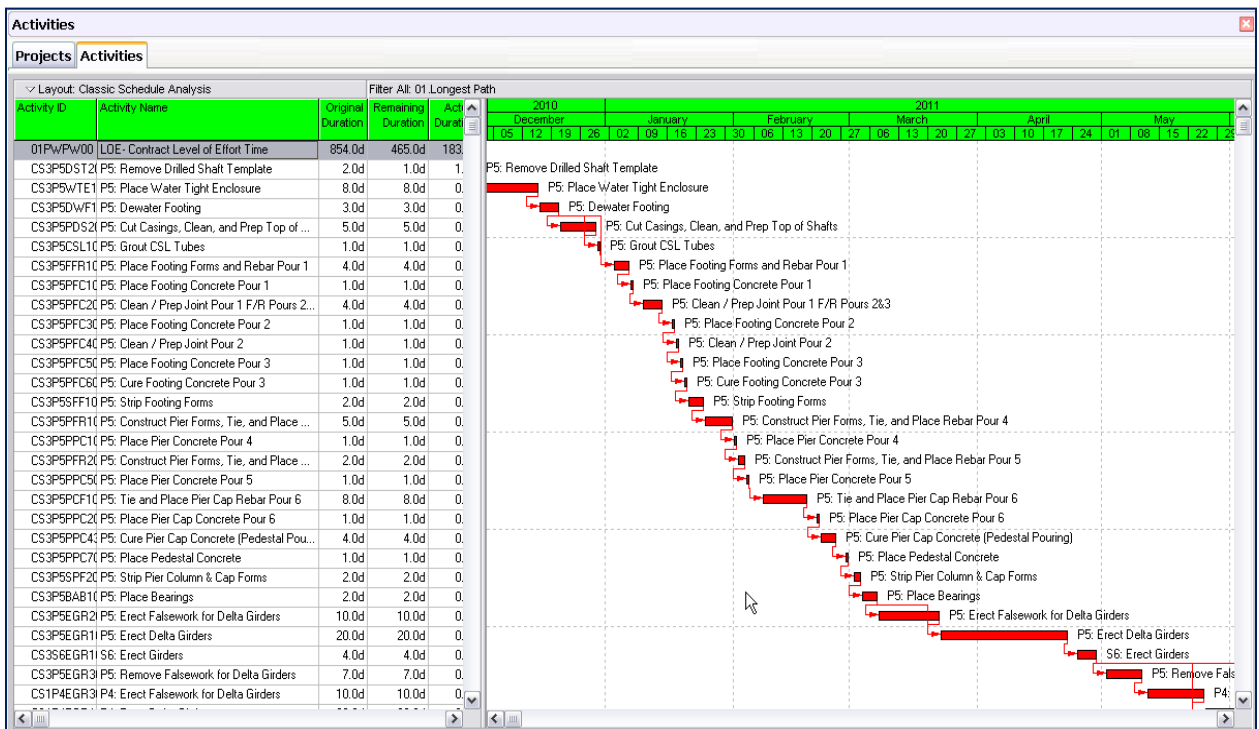

Steps:

In the **Toolbar**, click  to view the relationships between the activities.

Note: Even when relationships are modified or added, the activities will not move until the project is “scheduled”.

Introduction to Critical Path Method Scheduling using Primavera P6.1 Client for Construction

Viewing Relationships using Trace Logic

An activity may have a relationship from a predecessor that determines its Early Start. This logic tie is called a **driving relationship**.

- A solid relationship line indicates a driving relationship.
- A dashed relationship line indicates a non-driving relationship.

NYS DOT staff should use this information when you question the dates of a particular activity. Many times, after analysis, missing or inappropriate relationships will be found and corrected to establish a more realistic schedule.

The screenshot shows the Primavera P6.1 Activities window. The top part is a table with columns: Activity ID, Activity Name, Original Duration, Remaining Duration, Early Start, Start, Finish, Late Finish, Total Float, Free Float, and Calendar. The bottom part is a network diagram showing activity nodes and their relationships.

Activity ID	Activity Name	Original Duration	Remaining Duration	Early Start	Start	Finish	Late Finish	Total Float	Free Float	Calendar
C99902	Point Walls - 17th Street	10.0d	10.0d	09-Nov-10 ...	09-Nov-10 ...	22-Nov-10 ...	05-Jan-11 ...	27.0d	0.0d	D260688 - 5-Day Work Wk
C99900	Start Final Cleanup	0.0d	0.0d	09-Nov-10 ...	09-Nov-10 ...	09-Nov-10 ...	20-Dec-10 ...	27.0d	0.0d	D260688 - 5-Day Work Wk
C99904	Point Walls -18th Street	10.0d	10.0d	23-Nov-10 ...	23-Nov-10 ...	09-Dec-10 ...	19-Jan-11 ...	27.0d	0.0d	D260688 - 5-Day Work Wk
C99906	Point Walls - Ramp D	10.0d	10.0d	10-Dec-10 ...	10-Dec-10 ...	23-Dec-10 ...	03-Feb-11 ...	27.0d	0.0d	D260688 - 5-Day Work Wk
C99908	Point Walls - Ramp F	10.0d	10.0d	27-Dec-10 ...	27-Dec-10 ...	10-Jan-11 ...	18-Feb-11 ...	27.0d	0.0d	D260688 - 5-Day Work Wk
C99910	Point Walls - Hamilton Avenue	10.0d	10.0d	11-Jan-11 0...	11-Jan-11 ...	24-Jan-11 ...	07-Mar-11 ...	27.0d	0.0d	D260688 - 5-Day Work Wk
C99912	Repair Wrought Iron Fence	10.0d	10.0d	25-Jan-11 0...	25-Jan-11 ...	08-Feb-11 ...	21-Mar-11 ...	27.0d	0.0d	D260688 - 5-Day Work Wk
C99914	Place New Chain Link Fence + Gate 0B 3rd	5.0d	5.0d	09-Feb-11 ...	09-Feb-11 ...	16-Feb-11 ...	28-Mar-11 ...	27.0d	0.0d	D260688 - 5-Day Work Wk
C99916	Pave Mowing Strips	5.0d	5.0d	17-Feb-11 ...	17-Feb-11 ...	23-Feb-11 ...	05-Apr-11 ...	27.0d	0.0d	D260688 - 5-Day Work Wk
C99918	Place Root Barriers	5.0d	5.0d	24-Feb-11 ...	24-Feb-11 ...	03-Mar-11 ...	12-Apr-11 ...	27.0d	0.0d	D260688 - 5-Day Work Wk
C99920	Recondition Soil	5.0d	5.0d	04-Mar-11 ...	04-Mar-11 ...	10-Mar-11 ...	19-Apr-11 ...	27.0d	0.0d	w/w (LANDSCAPE - SPRING PLAT
C99922	Place Topsoil	5.0d	5.0d	07-Mar-11 ...	07-Mar-11 ...	11-Mar-11 ...	20-Apr-11 ...	27.0d	0.0d	w/w (LANDSCAPE - SPRING PLAT
C99924	Establish Turf	5.0d	5.0d	08-Mar-11 ...	08-Mar-11 ...	14-Mar-11 ...	20-May-11 ...	47.0d	20.0d	w/w (LANDSCAPE - SPRING PLAT
C99934	Plant 79 Trees	10.0d	10.0d	08-Mar-11 ...	08-Mar-11 ...	21-Mar-11 ...	28-Apr-11 ...	27.0d	0.0d	w/w (LANDSCAPE - SPRING PLAT
C99926	Plant 645 Shrubs	15.0d	15.0d	22-Mar-11 ...	22-Mar-11 ...	12-Apr-11 1...	20-May-11 ...	27.0d	0.0d	w/w (LANDSCAPE - SPRING PLAT

Steps:

1. Select activity **A04010**.
2. In the Tool Bar, click,  **Trace Logic**.

Introduction to Critical Path Method Scheduling using Primavera P6.1 Client for Construction

Mandatory and Discretionary Logic

Mandatory

It is a basic tenet of CPM that each activity must follow some order of execution. Logic dependencies influence work order. For example, *Form and Pour Concrete* activities. If *Form* is Activity A and *Pour Concrete* is Activity B then, they have a *Finish-to-Start* relationship.

A mandatory logic is a relationship between activities that cannot be broken. *Form* first before *Pour*. This is unavoidable, unmovable and always true. Hence, this logic is considered “mandatory.”

Physical Requirements

In the real world, this means that a successor activity can only start when the physical infrastructure upon which it will be built is in place courtesy of its predecessor activity making their relationship “mandatory.” “Activity B” cannot start without “Activity A” being finished. A formwork must be completed before concrete can be placed. The pipe must be installed before it can be backfilled.

Contractual Demands & Imposed Contractual Logic

When certain activity sequences must be done according to the contractual agreement, it definitely must follow a mandatory logic. If the contract specifies that Stage 1 must be done before work on Stage 2 can begin, this is a contractually-imposed mandatory logic. Incentive/Disincentive and B-Clock clauses are good examples of the contractual factors that demand this type of mandatory logic.

Discretionary (or Preferential)

Discretionary logic suggests “variation” in the sequencing and relationship ties between activities. In other words, there is no absolute rule that a successor activity is always dependent upon the predecessor activity.

Introduction to Critical Path Method Scheduling using Primavera P6.1 Client for Construction

During your project schedule review, consider that the contractor has flexibility in his plan to build the project. Part of your review is to make a determination whether the discretionary logic being proposed is reasonable or not.

Examining the Logic Ties

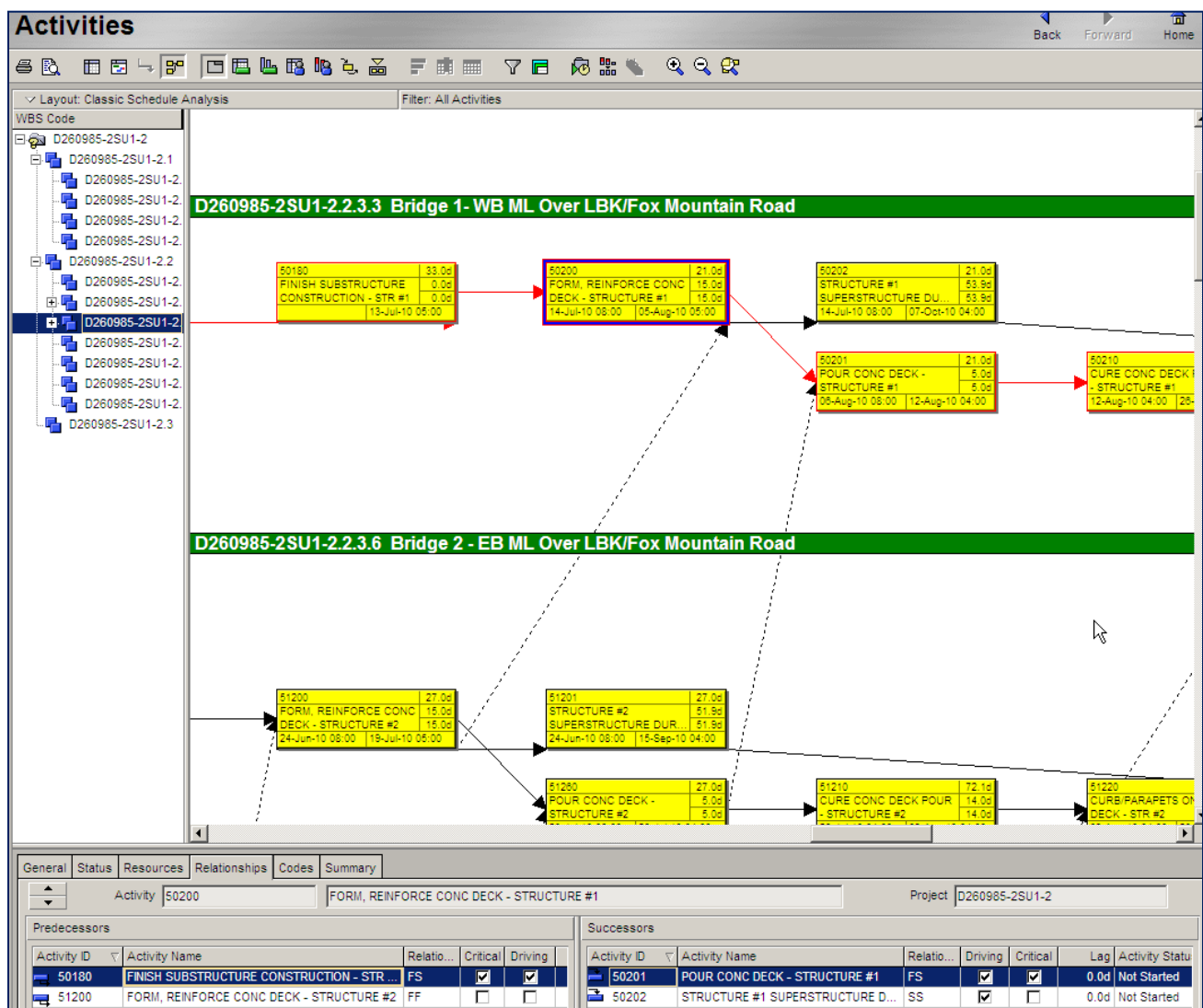

Introduction to Critical Path Method Scheduling using Primavera P6.1 Client for Construction

Lesson 6: Analyzing Relationships

Review Questions

1. Define “lag”.
2. **True or False: Specification 2. Baseline Progress Schedule @ Award** stipulates that lag time may not exceed 10 days.
3. What should the project scheduler do as an alternative to having a lag of more than 10 days?
4. What are the differences between a **Mandatory** and **Discretionary** logic?
5. What types of logic ties are appropriate for the predecessors to the Substantial Completion activities?
6. In Primavera, how can you tell whether an activity has a **Start-to-Start** relationship with another activity?

**Introduction to Critical Path Method Scheduling
using Primavera P6.1 Client for Construction**

Lesson 7:

CPM Scheduling Concepts

Objectives

**This lesson describes how schedule dates are calculated.
At the completion of this lesson, you will be able to:**

- **Perform a forward and backward pass**
- **Define float and its impact on a schedule**
- **Identify loops and open ends**
- **Calculate a schedule**
- **Analyze the scheduling log report**
- **Understand the importance of “scheduling” the project and reviewing the electronic schedule file instead of a paper plot generated by contractor**

<i>Key Terms</i>
<i>Forward Pass</i>
<i>Backward Pass</i>
<i>Total Float</i>
<i>Driving Relationship</i>
<i>Loop</i>
<i>Early Dates</i>
<i>Late Dates</i>

Introduction to Critical Path Method Scheduling using Primavera P6.1 Client for Construction

Critical Path Method (CPM) Scheduling

Excerpt from Paragraph (B. Scheduling Software)

The Department will provide the Contractor either a Preliminary Construction Schedule or a project schedule template for the Contractor's use in developing their CPM Progress Schedule. The Contractor shall develop, update, and revise the Progress Schedules using Primavera P6 software that has been loaded on the Department's network servers and the Contractor shall store all Progress Schedule files on the Department's network servers.

The Critical Path Method (CPM) scheduling technique is utilized to calculate NYSDOT schedules. CPM uses activity durations and relationships between activities to calculate schedule dates. This calculation is done in two passes through the activities in a project.

Critical Path

- The critical path is the path of activities through a project that determines the project duration and therefore, the anticipated project completion date.
- A delay in one activity delays other activities and the project as a whole.
- Primavera allows users to calculate the critical path either total float or the longest path in the project. However, **NYSDOT requires the Contractor to schedule the project using the *Longest Path* and not *Total Float* when determining the Critical Path.**

NYSDOT staff will use the Critical Path to focus on to determine if the project will finish on time or not. If the project is not going to finish on time, modifying non-critical activities will not help in bringing the project back on schedule.

FOCUS ON THE CRITICAL PATH!

Introduction to Critical Path Method Scheduling using Primavera P6.1 Client for Construction

What is the Data Date?

Excerpt from Paragraph 4.c.i (Monthly Progress Schedule Submission):

i) **Data Date** - the “Data Date” shall be the date the Project Scheduler last edits the schedule prior to submission to the Engineer (generally the last working day of the contract payment period). The Project Scheduler can modify the project’s Data Date through the Schedule tool.

- The date used as the starting point for scheduling calculations.
- The date used to schedule all future work.
- For the baseline progress schedule submittal, the data date shall be the contractor award date.
- For monthly progress schedule submittal, the data date shall be consistent with the last working day of the monthly contract payment period.

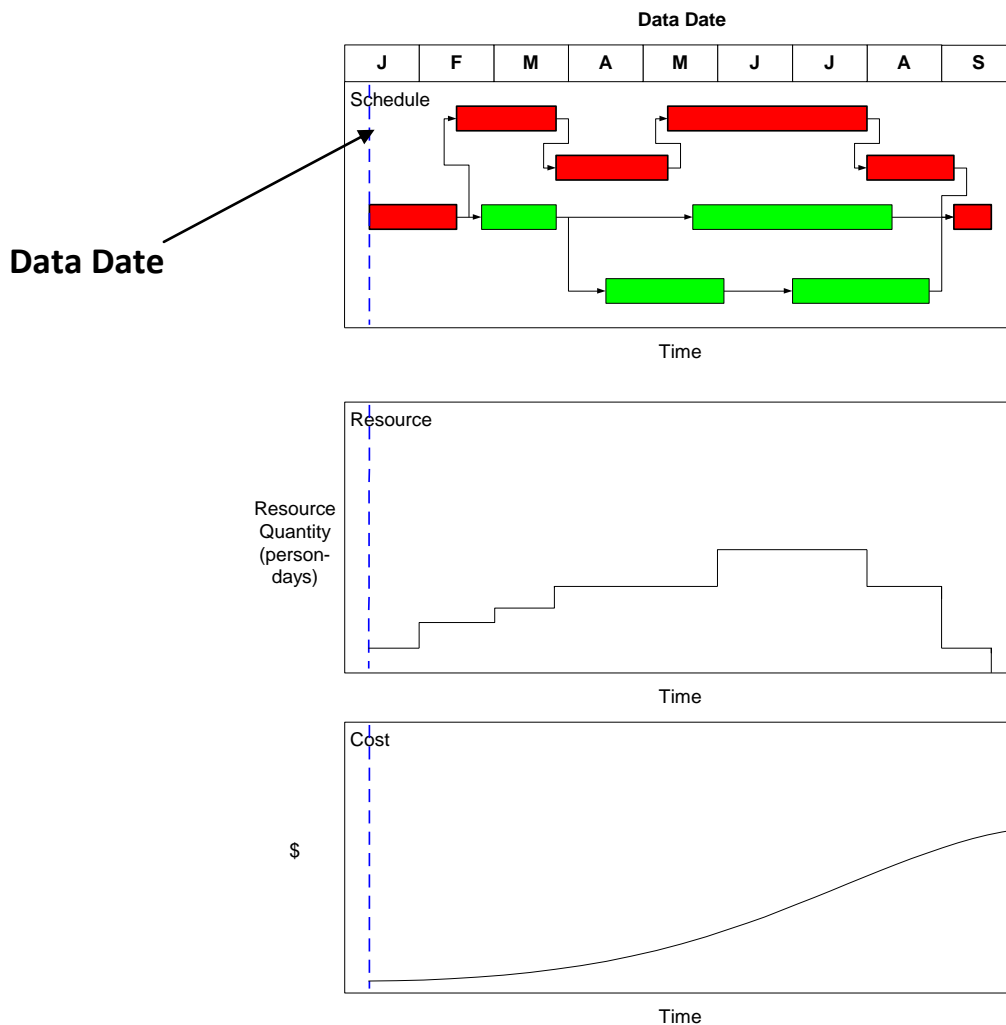

Introduction to Critical Path Method Scheduling using Primavera P6.1 Client for Construction

Scheduling Concepts

Forward Pass

- Calculates an activity's early dates.
- Early dates are the earliest times an activity can start and finish once its predecessors have been completed.
- The calculation begins with the activities without predecessors.
- **Early Start + Duration - 1 = Early Finish**

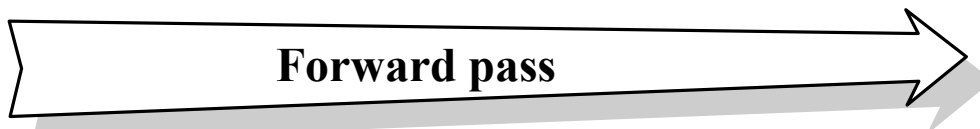
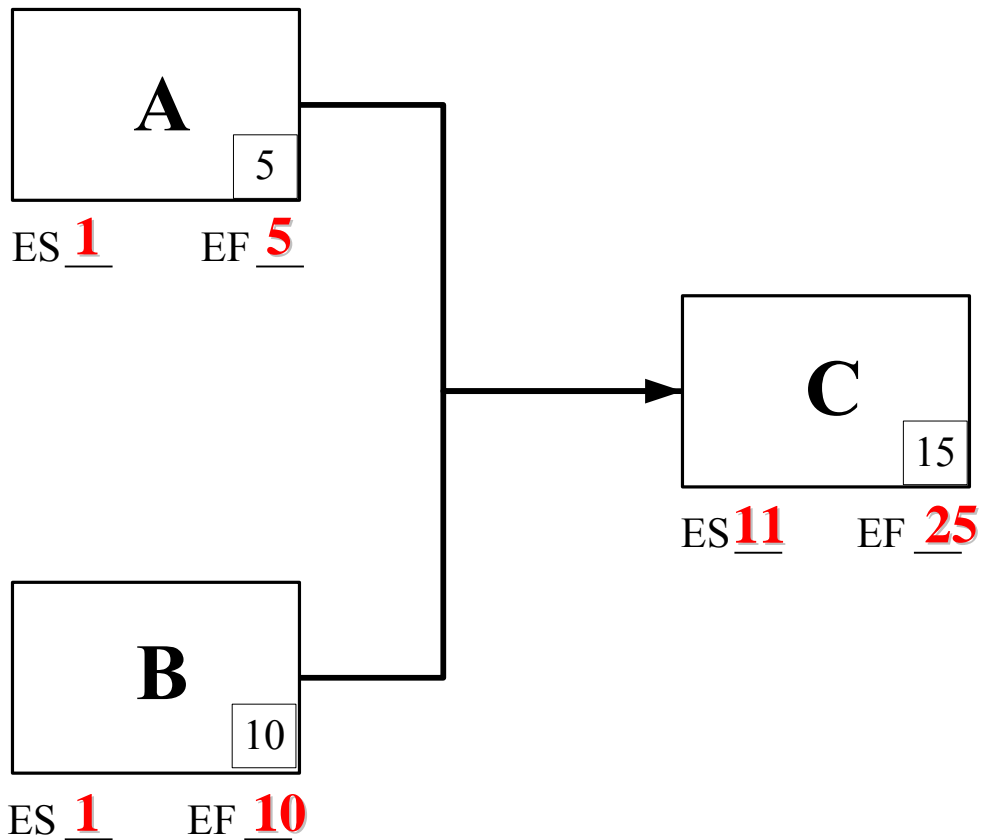

Introduction to Critical Path Method Scheduling using Primavera P6.1 Client for Construction

Backward Pass

- Calculates an activity's late dates.
- Late dates are the latest times an activity can start and finish without delaying the end date of the project. The late dates are the NYSDOT contractual dates.
- The calculation begins with the activities without successors.
- **Late Finish - Duration + 1 = Late Start**



LS6 LF 10

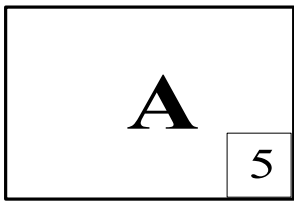

ES1 EF 5

LS1 LF 10

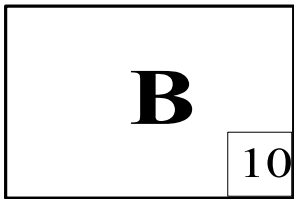

ES1 EF 10

LS11 LF 25

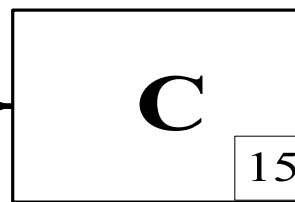

ES 11 EF 25

Introduction to Critical Path Method Scheduling using Primavera P6.1 Client for Construction

Total Float

- The amount of time an activity can slip from its early start without delaying the project.
- The difference between an activity's late dates and early dates.
- Activities with zero total float are critical.
- Late date – Early date = Total Float (TF)

Excerpt from Paragraph J.1,2, & 5 (Float):

During the course of contract execution, Total Float generated due to the efficiencies of either party (State or Contractor) will generally be considered Project Float that is not for the sole use of the party generating the float; rather it is a shared commodity to be reasonably used by either party. Any party assigned activity responsibility within the schedule has the full use of the Project Float until it is depleted.

However, if the Contractor submits a request for an Early Completion that includes a revised Progress Schedule supplemented with resource allocations for each task activity and time-scaled resource histograms that is accepted by the Department, then Total Float actually resulting from additional Contractor resources, additional work shifts, longer work weeks or adoption of more aggressive scheduling and construction management practices of the Contractor's work activities may be considered Contractor Owned Float for the exclusive use of the Contractor. Refer to paragraph I for resource loading requirements for Early Completion Dates.

For either the State or Contractor to reserve Total Float as State Owned Float or Contractor Owned Float the party must document within the schedule submission narrative in advance of generating the Total Float the additional resources or measures that will taken to shorten the critical path, and then document within the schedule submission narrative that immediately followed when the Total Float was actually generated the change to State or Contractor owned float based on entry of Actual Start and Actual Finish dates and percentage of work completed, and this must be agreed to by both parties in the next project Progress Meeting. Without this timely documentation any Total Float generated will be considered project float.

Introduction to Critical Path Method Scheduling using Primavera P6.1 Client for Construction

Positive float

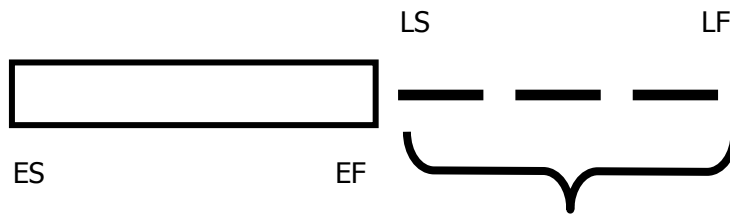

Positive float

**Zero float
(critical)**

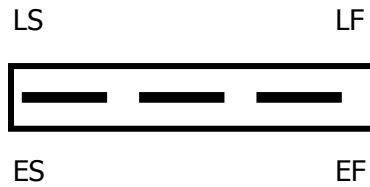

**Negative Float
(extremely
critical)**

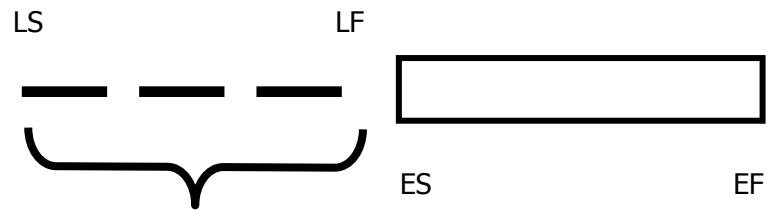

Negative float

Introduction to Critical Path Method Scheduling using Primavera P6.1 Client for Construction

Total Float (*continued*)

An activity's total float is automatically calculated each time you schedule the project. You cannot edit an activity's float values directly.

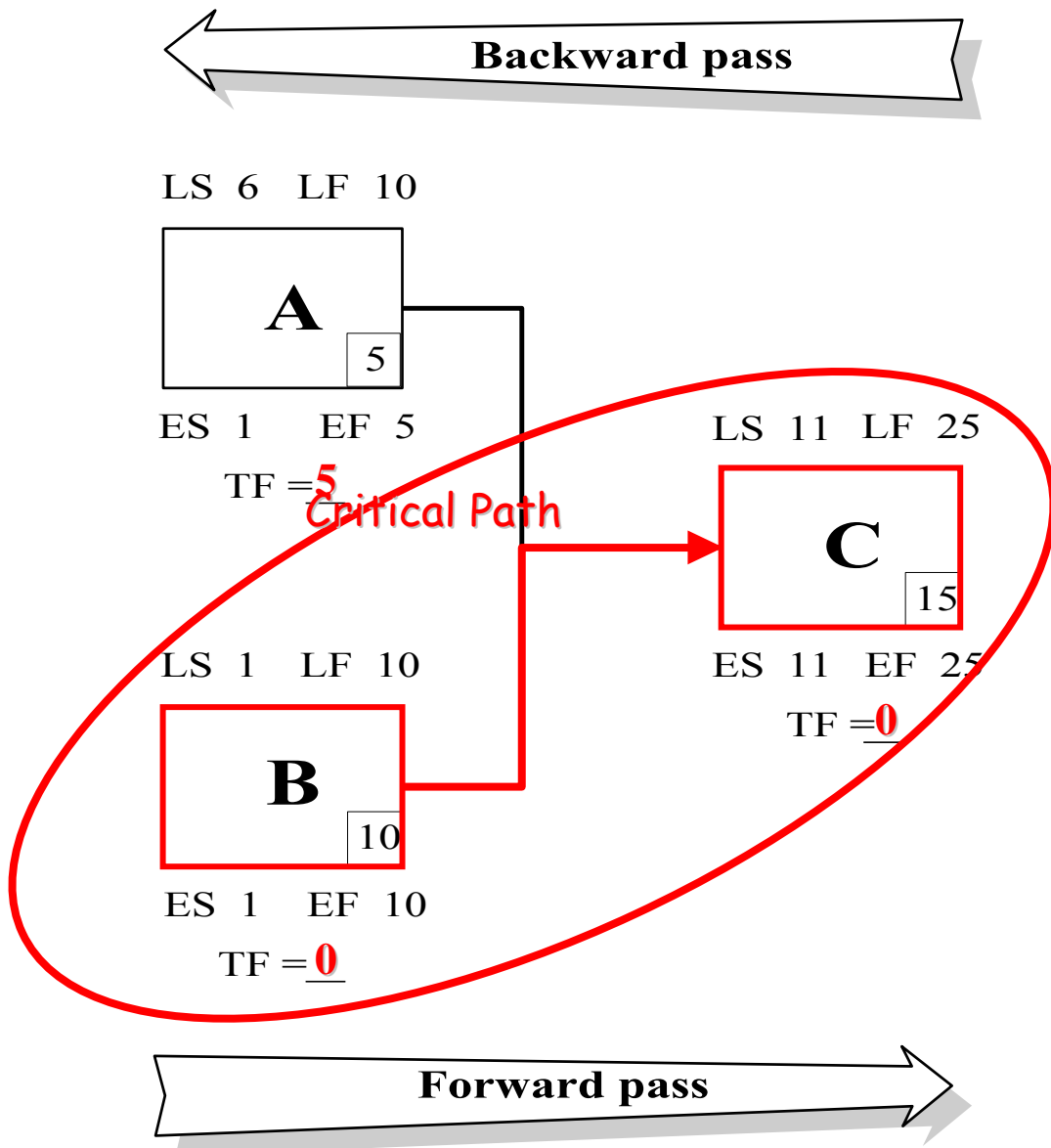

Introduction to Critical Path Method Scheduling using Primavera P6.1 Client for Construction

Backward Pass with Required Finish

- One of the most common NYSDOT project scenarios is a contract (completion date) “Must Finish by” date for the project.
- Used only during the backward pass.
- Required finish date specifies when the project must finish regardless of the network’s duration and logic.
 - Contractor should not submit a baseline schedule with negative float.

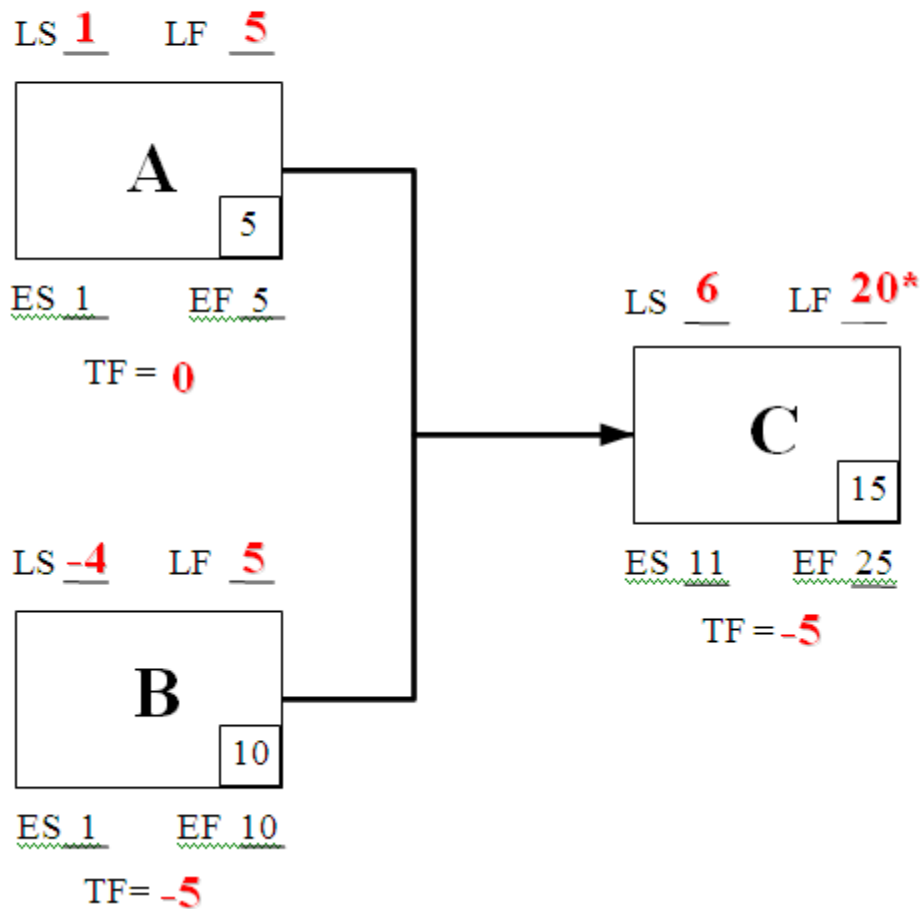

Introduction to Critical Path Method Scheduling using Primavera P6.1 Client for Construction

Open Ends

- Activities without a predecessor or successor.
 - No predecessor - activity uses data date as its early start
 - No successor - activity uses project finish as its late finish
- Open ended activities can portray an unrealistic amount of positive total float.

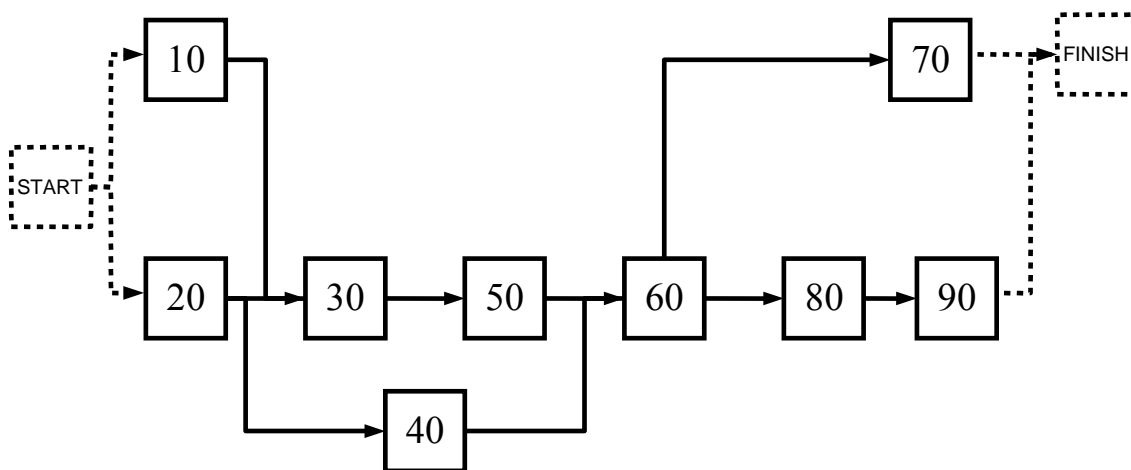

NOTE: NYSDOT requires that each project have only two open ends, the first activity and the last activity.

Excerpt from Paragraph 2.viii (Baseline Progress Schedule @ Award):

viii) **Activity Relationships** - Clearly assign predecessors and successors relationships to each activity, and assign appropriate logic ties between activities (Finish to Start, Start to Start, Finish to Finish, etc). Do not have any open ended activities, with the exception of the first activity and last activity in the schedule.

Introduction to Critical Path Method Scheduling using Primavera P6.1 Client for Construction

Scheduling a Project

When scheduling a project, activity dates are calculated according to duration and logic.

Click the **Log to file** checkbox to record scheduling results in a log file (.txt).

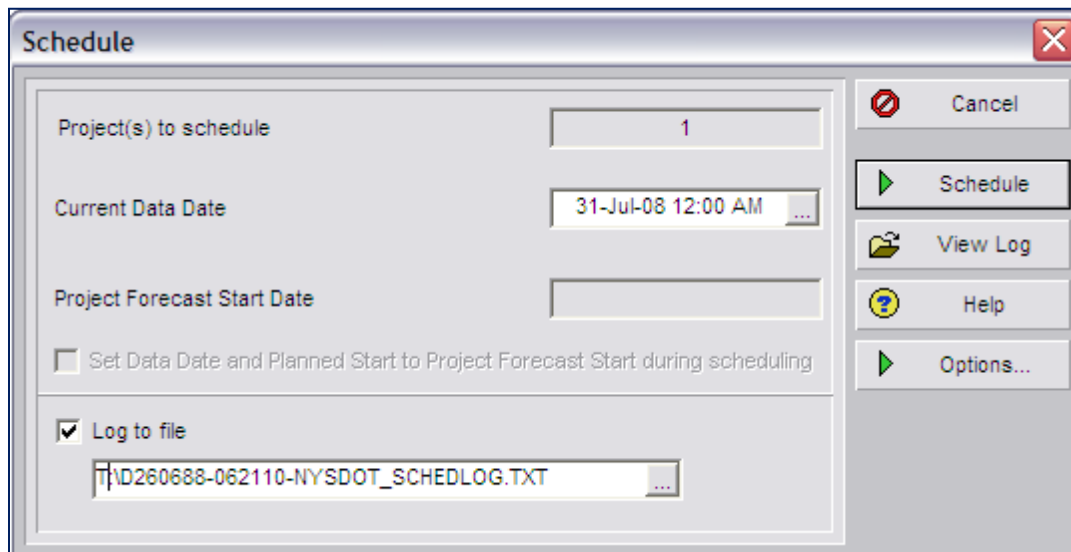

Steps:

1. Open project **D260688-ISUx**
2. In the **Directory Bar**, click on **Activities**
3. In the **Tools** menu, click **Schedule (or press F9)**
4. Accept the contractor's data date.
5. Ensure that the **Log to File** box is clicked.
6. Click **Schedule**.

Introduction to Critical Path Method Scheduling using Primavera P6.1 Client for Construction

Schedule Log

- Primavera generates a **Schedule Log** that displays:
 - *Scheduling/Leveling settings*
 - *Statistics*
 - *Errors*
 - *Warnings*
 - *Scheduling/leveling results*
 - *Exceptions*

```
D260688-Update1-NYSDOT_SCHEDLOG.TXT - Notepad
File Edit Format View Help
Scheduling/Leveling Report - 26-Jan-10 02:58 PM - PM.exe
-----
Default Project.....D260688-3APB
Projects:
D260688-3APB.....D260688
- Gowanus Expressway Rehabilitation - As Planned At Award Baseline - submitted 7/10/2008
-----
Scheduling/Leveling settings:
-----
General
-----
Scheduling .....Yes
Leveling .....No
Ignore relationships to and from other projects .....Yes
Make open-ended activities critical .....No
Use Expected Finish Dates .....Yes
Schedule automatically when a change affects dates .....No
Level resources during scheduling .....No
Recalculate assignment costs after scheduling .....No
when scheduling progressed activities use .....Retained Logic
Calculate start-to-start lag from .....Early Start
Define critical activities as .....Longest Path
Compute Total Float as .....Finish Float
Calendar for scheduling Relationship Lag .....Successor
Activity Calendar
-----
Advanced
-----
calculate multiple float paths.....No
-----
Statistics:
-----
# Projects.....1
# Activities.....1639
```

Steps:

1. In the **Tools** menu, click **Schedule (or press F9)**.
2. Click **View Log**.
3. Go to the **Activity Layout** and display **2 Week Lookahead** Layout.

Excerpt from Paragraph 4.d.xix (Monthly Progress Schedule Submission):

APPENDIX 2 – A complete Scheduling/Leveling Report (SCHEDLOG.TXT file generated by the Department's Primavera scheduling software application) which includes the Schedule Settings, Statistics, Errors, Warnings, Scheduling/Leveling Results, Exceptions, Activities with unsatisfied constraints, Activities with unsatisfied relationships, and Activities with external dates. The statistics shall include, # of Activities, # of Activities Not Started, # of Activities In Progress, # of Activities Completed, # of Activity Relationships, and # of Activities with Constraints. Total number of activities on the critical path, percent complete, activities without predecessors, activities without successors, and activities out of sequence.

Introduction to Critical Path Method Scheduling using Primavera P6.1 Client for Construction

Lesson 7: CPM Scheduling Concepts

Review Questions

1. Explain “**Early Start**.”
2. Typically, an effective CPM-scheduled project should only have two open-ended activities. What are these?
3. How do you calculate the “**float**”?
4. How much **float** should there be in the critical path? Why?
5. When scheduling a project in Primavera, where do you select the different scheduling options? What are the NYSDOT requirements regarding these options?

Introduction to Critical Path Method Scheduling using Primavera P6.1 Client for Construction

Lesson 8:

Evaluating Constraints

Objectives

**This lesson provides the definition and usage of a constraint.
At the completion of this lesson, you will be able to:**

- **Identify the different types of constraints**
- **Review project schedule constraints**
- **Evaluate when and when not to use constraints**

Introduction to Critical Path Method Scheduling using Primavera P6.1 Client for Construction

Defining Constraints

Constraints are imposed date restrictions used to reflect project requirements that cannot be built into the logic.

NYSDOT allows constraints that are in the contract such as project completion date and B clock dates. Other constraints must be approved by the NYSDOT.

Constraints are used to build a schedule that more accurately reflects the real-world aspects of the project, provide added control to the project, and impose a restriction on the entire project or an individual activity. Typically, only contractual constraints such as the contract completion date will be allowed in the original baseline schedule. The EIC needs to identify and approve any constraints used in the schedule. Upon approval by the EIC, the contractor may add constraints in monthly progress schedule to reflect situations **such as dates provided for in a Utility Relocations Agreement, etc.** Many times when Contractor's state they need a constraint for an activity where a date needs to be met in the contract, instead these dates just need to be monitored to assure that they are not exceeded.

- **Constraints are user-imposed.**
- **Two constraints can be assigned to an activity.**
- **After applying a constraint, the project must be rescheduled to calculate the new dates.**

Excerpt from Paragraph 2.d.x (Baseline Progress Schedule @ Award):

x) **Activity Constraint Dates** – The Contractor shall not have any constrained activities, with the exception of contractual dates, unless the Engineer accepts such constraints in writing. Milestone activities shall be included for the Contract Award which shall have a primary constraint of “Finish On” and the date of contract signature by the State Comptroller, and for the Contract Completion which shall have a primary constraint of “Finish on or before” and the contract completion date indicated in the contract documents. Only contractual/owner-designated constraints are allowed unless specifically authorized by this specification or the Engineer.

Note: For specification reference, go to the 1st paragraph of page 145

Introduction to Critical Path Method Scheduling using Primavera P6.1 Client for Construction

Commonly Used Constraints

Must Finish By (*Required per NYSDOT specification*)

This is a project-level constraint that is used when an overall project deadline (contract completion date) must be met.

The program will attempt to schedule all activities in the project to finish by the date specified.

It will calculate the Late Finish Dates in a Backward Pass when scheduling the project.

The Must Finish By date will be entered in the Dates tab of the Projects view. Only NYSDOT admin staff can perform this action.

The field office staff needs to accept a baseline schedule that reflects no negative Total Float before the Contractor submits Monthly Progress schedule.

When an Extension of Time is recommended by the EIC, the EIC needs to notify the CPMSchedulingSection@dot.state.ny.us to modify this date.

The screenshot shows the 'Dates' tab in the Primavera P6.1 Client. The interface is divided into two main sections: 'Schedule Dates' and 'Anticipated Dates'. The 'Schedule Dates' section contains several date fields: 'Project Planned Start' (20-Mar-08 00:00), 'Data Date' (31-Jul-08 00:00), 'Actual Start' (20-Mar-08 00:00), 'Must Finish By' (31-Dec-11 17:00), and 'Finish' (28-Dec-11 17:00). The 'Anticipated Dates' section contains two empty date fields: 'Anticipated Start' and 'Anticipated Finish'. The top of the window shows a navigation bar with tabs for 'General', 'Dates', 'Notebook', 'Funding', 'Codes', 'Defaults', 'Resources', and 'Settings'.

Steps:

1. Open your project
2. In the **Directory Bar**, click **Projects**
3. Click the **Dates** tab.
4. Highlight your project
5. Click the **Ellipsis** box  in the **Must Finish By** field.
6. Select a date.
7. **Reschedule (F9)**.

Introduction to Critical Path Method Scheduling using Primavera P6.1 Client for Construction

Other Constraints

Start On or After

Use the *Start On or After* constraint to set the earliest date an activity can begin.

- Forces the activity to start no earlier than the constraint date.
- Pushes the early start date to the constraint date.
- Affects early dates of its successors.

Finish On or Before

Use the *Finish On or Before* constraint to set intermediate completion points in the project.

- Forces the activity to finish no later than the constraint date.
- Pulls the late finish date to the constraint date.
- Affects the late dates of its predecessors.

Start On

- Forces the activity to *start on* the constraint date.
 - Shifts both early and late start dates
 - Delays an early start or accelerates a late start.
 - Used to specify dates submitted by contractors or vendors.

Start On or Before

- Forces the activity to start no later than the constraint date.
 - Shifts the late start to the constraint date.
 - Affects the late dates of its predecessors.
 - Used to place a deadline on the start of the activity.

Introduction to Critical Path Method Scheduling using Primavera P6.1 Client for Construction

Other Constraints (*continued*)

Finish On

- Forces the activity to finish on the constraint date.
 - Shifts both early and late finish dates.
 - Delays an early finish or accelerates a late finish.
 - Used to satisfy intermediate project deadlines.

Finish On or After

- Forces the activity to finish no earlier than the constraint date.
 - Shifts the early finish to the constraint date.
 - Affects the early dates of its successors.
 - Used to prevent an activity from finishing too early.

As Late As Possible

- Delays an activity as late as possible without delaying its successors.
 - Shifts the early dates as late as possible.
 - Also called zero free float constraint.

Mandatory Start and Finish

- Forces early and late dates to be equal to the constraint date.
 - Affects late dates of predecessors and early dates of successors.
 - May violate network logic.
 - Not recommended for most projects.

Hard constraints such as Start On, Finish On and Mandatory Start and Finish should be avoided.

Introduction to Critical Path Method Scheduling using Primavera P6.1 Client for Construction

Reviewing Constrained Dates

To review the project completion constraint or any other date constraints:

Steps:

1. In the **Tools** bar, click  the filter icon.
2. Click **Any selected filter**.
3. Select **Has Start Constraint**.
4. Select **Has Finish Constraint**.
5. Click **OK**.

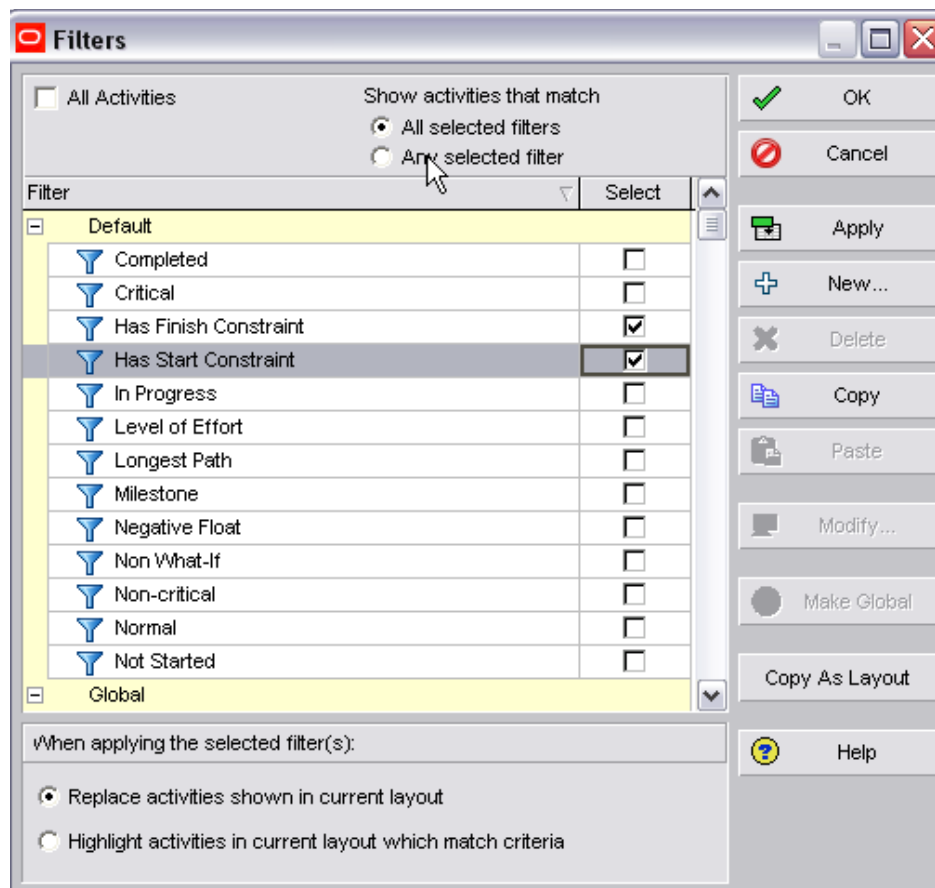

Introduction to Critical Path Method Scheduling using Primavera P6.1 Client for Construction

Lesson 8: Evaluating Constraints

Review Questions

1. As a standard specification, NYSDOT requires a **constraint** on what activity?
2. In Primavera's **Activity Details** layout, what tab has information about **constraints**?
3. Under **Specification 2. Baseline Progress Schedule @ Award, d, x**, how many constraints in the schedule can the Contractor create?
4. What are the effects of **Mandatory Start** and **Finish constraints**?
5. **True or False:** Unless approved by the EIC, a constraint cannot be put into the project schedule.
6. How should the EIC evaluate the effects of allowing a constraint to be added in the schedule?

Introduction to Critical Path Method Scheduling using Primavera P6.1 Client for Construction

Lesson 9:

Resource Analysis/Production Rates

Objectives

In this lesson, you will examine what activity resources are. At the completion of this lesson, you will be able to:

- **Define the three categories of a resource**
- **Create, review and assign resources to activities**
- **Explain the different NYSDOT Resource Loading requirements**

Excerpt from Specification 2. Baseline Progress Schedule @Award, d, xiv:

- xiv) **Activity Resources** – The Contractor will generally not be required to develop Labor resources, Equipment resources or Contract Pay Item resources in the Resource Dictionary, or assign them to schedule activities. The Contractor may be required by the Engineer to assign Labor and Equipment resources if submitting a Progress Schedule when contract milestone activities are projected to have Early Completion dates, as described in paragraph I of this specification. The Contractor will not be required to assign costs to resource assignments in the schedule. The Department will assume when reviewing the schedule that the Contractor's resources are unlimited; unless the Contractor either assigns equipment, labor and contract pay item resources to each activity in the schedule (and performs resource leveling), or indicates in the schedule narrative what resource limitations are present. If labor, equipment and contract pay item resources are not assigned to activities in the schedule, it shall be the Contractor's responsibility to assure the activity logic in the schedule properly reflects their resource limitations. If labor and equipment resources are not assigned to activities in the schedule, and the Contractor anticipates multiple crews for the same schedule activity, these resources shall be documented in the schedule narrative. As an activity can have only one responsible party, no activity shall involve multiple crews comprised of the Contractor and a subcontractor, or multiple subcontractors.

Introduction to Critical Path Method Scheduling using Primavera P6.1 Client for Construction

Continued:

Excerpt from Item Specification 2. Baseline Progress Schedule @Award, d, xix:

- xix) **Narrative** - Include a narrative in Microsoft Word and/or Adobe Acrobat format that describes:
- The Contractor's general approach to construct the Work outlined in the baseline schedule. Address the reasons for the sequencing of work and describe any resource limitations, potential conflicts, and other salient items that may affect the schedule and how they may be resolved.
 - If not provided in the contract plans, or if modified by the Contractor, provide copies of the appropriate contract plan sheets marked up as Key Plans, to correlate values on the contract plans (for Area of Work, Stage of Work, and WZTC Phase) to the Contractor's planned breakdown of the project (ie- Activity Codes, Activity Descriptions) for scheduling purposes.
 - The justification(s) for each activity with a duration exceeding 15 working days.
 - The reason for any lags assigned to any activities.
 - The justification(s) for Contractor imposed activity constraints proposed in the schedule.
 - A list of calendars which have been used in the schedule, along with the general reason for their use.
 - The project critical path and challenges that may arise associated with the critical path.
 - Anticipated coordination issues related to work activities by other entities, that require additional information from or action by the Engineer.
 - Appendix 1 to the narrative shall be the "Schedule Log" report created when the project was scheduled.
 - Appendix 2 to the narrative shall be an electronic schedule plot (Adobe Acrobat format) using the Global Layout named "Baseline Schedule submission", with activities sorted by Start Date in ascending order, Grouping of activities by WBS, and only the "Longest Path" filter applied. This plot shall provide a clear critical path from the Data Date to the last activity in the schedule.

Introduction to Critical Path Method Scheduling using Primavera P6.1 Client for Construction

Defining Resources

A resource is anything used to complete an activity.
Resources are divided into three categories:

- **Labor** (people, crews)
 - Measured in units of time.
 - Generally reused between activities/projects.
 - Exception will be individual contractor's resources.
 - Recorded in terms of days or hours (e.g. \$50.00/hour)
- **Nonlabor** (Equipment)
 - Measured in units of time.
 - Recorded in terms of days or hours (e.g. \$465.00/hour)
- **Material** (*contract pay items*)
 - Measured in units other than time, meters, square meters, etc.
(e.g. \$4.50/square foot.)

The contractor is responsible to meet the NYSDOT specification to resource load their schedules based on project type and contract requirements.

For NYSDOT, different projects can have different Resource Loading requirements:

For Type 1 Non CPM Progress Schedules – No resource loading required ever.

For Type 2 CPM Progress Schedules – Generally no resource loading required.
However, if a Recovery Schedule or Early Completion Schedule is requested then, resource loading must be presented.

For Type 3 CPM Progress Schedules – Resource loading required for Labor resources at the Crew level & Equipment resources for specialty equipment.

For Type 4 CPM Progress Schedules – Resource loading required for Labor resources at the Title Classification level, Equipment resources , and Pay Item resources.

Introduction to Critical Path Method Scheduling using Primavera P6.1 Client for Construction

Viewing the Resource Dictionary

The Resources window contains information about all resources within NYSDOT, allowing for centralized resource management. Contractors will still be able to load their schedules with their approved resources that meet their contract specs.

The screenshot shows the Primavera P6.1 Resources window. The window has a tabbed interface with 'Resources' selected. The main area displays a table of resources with columns for Resource ID, Resource Name, Resource Type, Unit of Measure, Primary Role, and Default Units / Time. The resources are organized into a tree view on the left, starting with 'PRIME CONTR' and including various contractors and equipment. The 'M867-EXCAVATOR MINI' resource is highlighted. Below the table, there are tabs for 'General', 'Codes', 'Details', 'Units & Prices', 'Roles', 'Notes', and 'Progress Reporter'. The 'General' tab is active, showing options for Resource Type (Labor, Nonlabor, Material), Unit of Measure, Currency (Dollar), and Overtime Allowed. The Profile section shows the Calendar set to 'Standard 5 Day 10 Hour Workweek' and Default Units / Time set to 100%. Checkboxes for 'Auto Compute Actuals' and 'Calculate costs from units' are checked.

Resource ID	Resource Name	Resource Type	Unit of Measure	Primary Role	Default Units / Time
PRIME CONTR	PRIME CONTRACTORS	Labor			100%
HASA	Hasa Construction	Labor		Prime Contractor	100%
Bette	Bette & Cring, LLC	Labor			100%
Argenio Brothers	Argenio Brothers Inc.	Labor			100%
A Servidone/B Anthon	A Servidone/B Anthony Construction JV	Labor			100%
B & C	Bette & Cring	Labor			100%
ROUT - Root	Resources for project ROUT	Labor			100%
Beaver	Beaver Concrete Co.	Labor			100%
Bove	Bove Industries	Labor			100%
D260978	Route 112 Reconstruction Pine Road	Labor			100%
CCI	CCI Companies Inc	Labor			100%
D260867	Route 37B Messena Village	Labor			100%
M867 Equipment	M867 Equipment	Nonlabor			100%
M867-GRADALL	GRADALL	Nonlabor			100%
M867-EXCAVATOR MINI	EXCAVATOR-MINI	Nonlabor			100%
M867-RACK TRUCK	RACK TRUCK	Nonlabor			100%
M867-WHEELHOE	WHEELHOE	Nonlabor			100%
M867-D9	D9	Nonlabor			100%

Steps:

1. Open your project.
2. In the **Directory bar**, click **Resources**.

Introduction to Critical Path Method Scheduling using Primavera P6.1 Client for Construction

Resource Details

Use Resource Details to add, view, and edit detailed information about the selected resource.

The resource tabs show all of the information maintained for each resource. NYSDOT staff should be aware that there is an option on the *Details* tab that allows for *Auto Compute Actuals*. This is marked to automatically calculate the resource's actual quantity of work according to the project plan. This means that the resource usage was exactly as it was planned, rarely the case. An exception would be if the contractor is working on a set amount regardless of his actual usage. Depending on your project requirements, you may want the contractor to turn that option OFF.

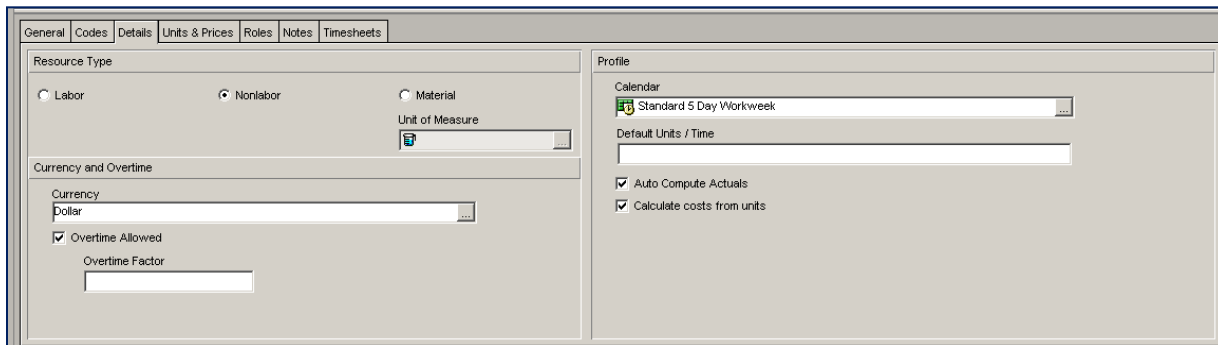

The screenshot shows the 'Resource Details' dialog box in Primavera P6.1. The 'Details' tab is selected. The 'Resource Type' section has radio buttons for 'Labor' (unselected), 'Nonlabor' (selected), and 'Material' (unselected). Below this is a 'Unit of Measure' dropdown menu. The 'Currency and Overtime' section includes a 'Currency' dropdown set to 'Dollar', a checked 'Overtime Allowed' checkbox, and an 'Overtime Factor' input field. The 'Profile' section on the right shows a 'Calendar' dropdown set to 'Standard 5 Day Workweek', a 'Default Units / Time' dropdown, and two checked checkboxes: 'Auto Compute Actuals' and 'Calculate costs from units'.

Steps:

Click the **Details** tab.

Introduction to Critical Path Method Scheduling using Primavera P6.1 Client for Construction

Creating Resources

Steps:

1. On the **Directory Bar**, click **Resources** button.



2. On the **Command Bar**, click the **Add** button.

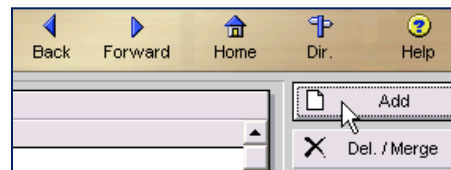

3. On **Resource Wizard** window, type the **ID** and **Name** of the resource.



4. Select the **Resource Type**.

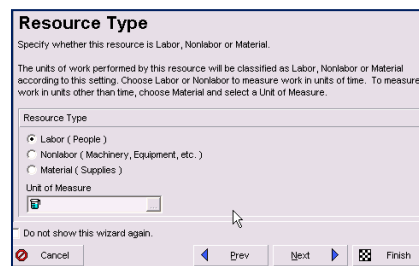

7. Select **Units/Time & Prices, Phone and Email, Roles, Resource Calendar, Auto-Compute Actuals**, etc.

8. When you get to the **Congratulations** screen, click **Finish**.



Introduction to Critical Path Method Scheduling using Primavera P6.1 Client for Construction

Assigning Resources

Steps:

1. Select an Activity.

2. Click the **Resources** tab in the **Activity Details Form**.

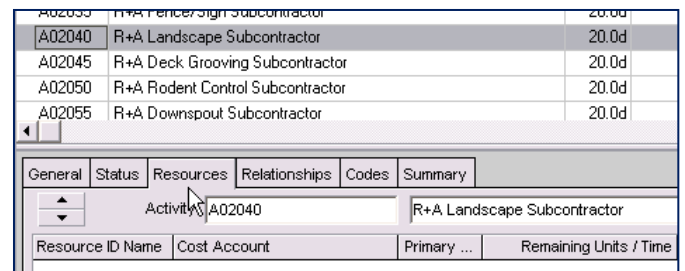

3. Click the **Add Resource** button.



4. Select the **Resource** to be assigned to the Activity

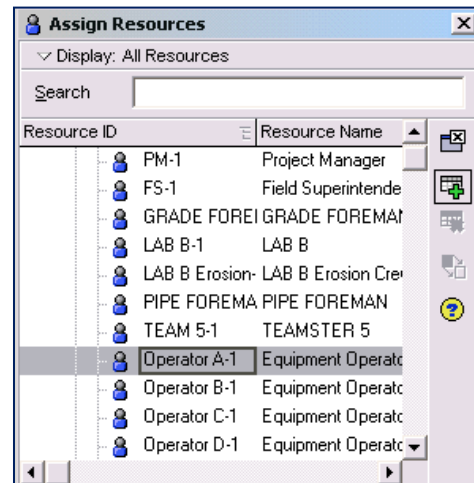

5. Click the **Assign** icon.



Introduction to Critical Path Method Scheduling using Primavera P6.1 Client for Construction

Analyzing Resources for NYSDOT

Resources are assigned, typically, at the activity level. When evaluating the contractor's resource loading, care should be taken to determine if a reasonable number of resources are assigned to the particular activity especially when the same resources are used on activities that are scheduled to happen at the same time. For example, if the contractor has one crane and that crane is assigned full time to three activities that are scheduled to happen at the same time. The schedule would require 3 cranes for that time period, when only one is available. If you feel that the amount of work can be reasonably be accomplished by the one crane, then it should be assigned to each of the three activities 33% each.

Cost Accounts, which correlate to the NYSDOT Contract Pay Item, are assigned for each resource.

Special note: resources can also be assigned to *WBS Summary* activity types. This allows the contractor, if authorized, to make these assignments at a higher level than the activity level.

Resource ID Name	Primary ...	Resourc...	g Units / Time	Original Lag	Start	Finish	udgeted Units	ctual Regular Units	remainir
61101011 (2560-2620) PLANTING TF	<input type="checkbox"/>	Material	0d	0.0d	02-Mar-04	15-Mar-04	0	0	
C0623 (61101011) PLANTING TF	<input type="checkbox"/>	Material	911d	0.0d	02-Mar-04	15-Mar-04	9108	0	
MANHOUR1.SUBCONTRACTOR	<input checked="" type="checkbox"/>	Labor	9d	0.0d	02-Mar-04	15-Mar-04	90d	0d	

Steps:

To view an activities resource assignments,

1. Select the activity.
2. Click the **Resources** tab in the **Activity Details Form**.

Introduction to Critical Path Method Scheduling using Primavera P6.1 Client for Construction

Analyzing Costs for NYSDOT

NYSDOT does not currently require the Contractor to COST load their schedules.

Where required, material quantities and activity costs will be used to verify the reasonableness of the activity durations and to ensure that all work required by the contract is accounted for within the schedule.

Costs, in Primavera, are planned and managed at the activity level.

There are two types of costs:

- **Resource** – Calculated based on resource assignments.
- **Expense** – Lump sum costs that are manually entered.

Resource

The cost of a resource can be calculated based on the price/unit defined in the resource dictionary and the Budgeted Units assigned to the activity.

$$\text{Budgeted Cost} = \text{Budgeted Units} \times \text{Price/Unit}$$

Resource ID Name	Primary ...	g Units / Time	Original Lag	Start	Finish	udgeted Units	ctual Regular Units
61101011 (2560-2620) PLANTING TREES/SHRUBS	<input type="checkbox"/>	0/d	0.0d	02-Mar-04	15-Mar-04	0	0
C0623.(61101011) PLANTING TREES/SHRUBS	<input type="checkbox"/>	911/d	0.0d	02-Mar-04	15-Mar-04	9108	0
MANHOUR1.SUBCONTRACTOR MANHOURS	<input checked="" type="checkbox"/>	9d/d	0.0d	02-Mar-04	15-Mar-04	90d	0d

Introduction to Critical Path Method Scheduling using Primavera P6.1 Client for Construction

Resource Analysis Settings

- Determine the level of detail displayed on resource usage profiles/spreadsheets.
- **All Projects**
 - All closed projects – select to display resource/cost usage across all projects that have been summarized in the Project Structure
 - Open projects only – select to focus on resource/cost usage in the projects currently opened on screen
- **Time-Distributed Data**
 - Display data based on *Remaining Early* or *Forecast* dates
 - Select the time interval for storing live resource allocations: Hour, Day, Week, Month

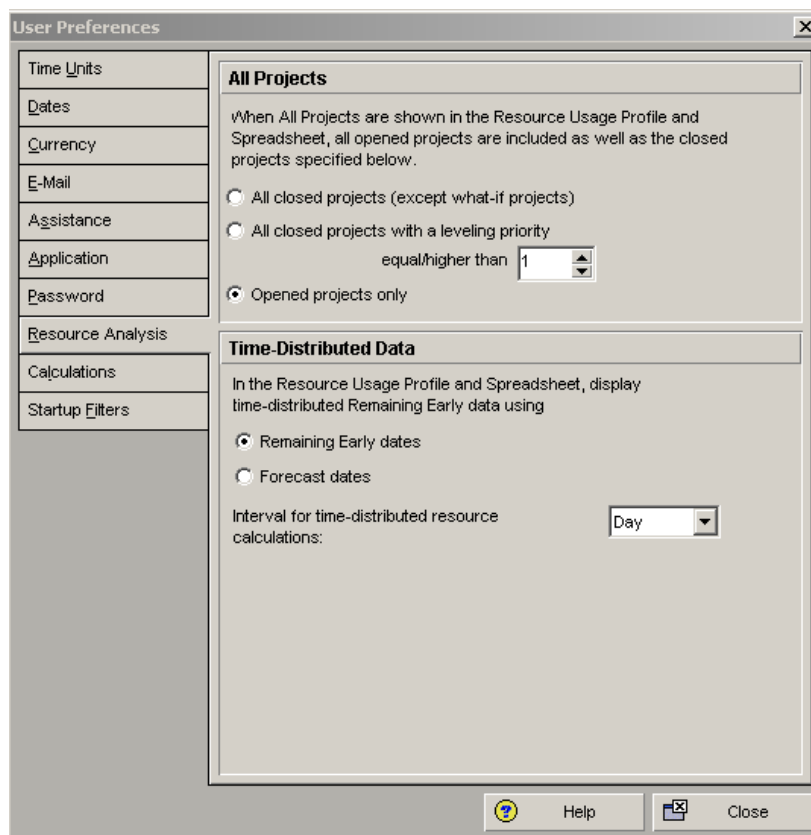

Steps:

1. In the **Edit** menu, click **User Preferences**.
2. Click the **Resource Analysis** tab.

Introduction to Critical Path Method Scheduling using Primavera P6.1 Client for Construction

Resource Usage Profile

The Resource Usage Profile provides a graphical view of unit/cost distributions over time. It displays the amount of effort the contractor has assigned for each resource on the project during each time period.

Use the profile to determine how many hours each resource is scheduled to work; identify over-allocated resources; track expenditures per time period; and display a “banana curve to compare early and late dates.

- View unit/cost distributions from a specific project or across all projects in the Project Structure.
- View resource or role allocations.
- Can display separate bars for one or all of the following:
 - Budgeted units/costs
 - Actual units/costs
 - Remaining Early units/costs
 - Remaining Late units/costs.
- The Resource Usage profile timescale matches the timescale for the Gantt Chart.
- Format columns, group, sort, and filter resources in the profile.
- The Resource Usage profile can be saved as part of the layout.

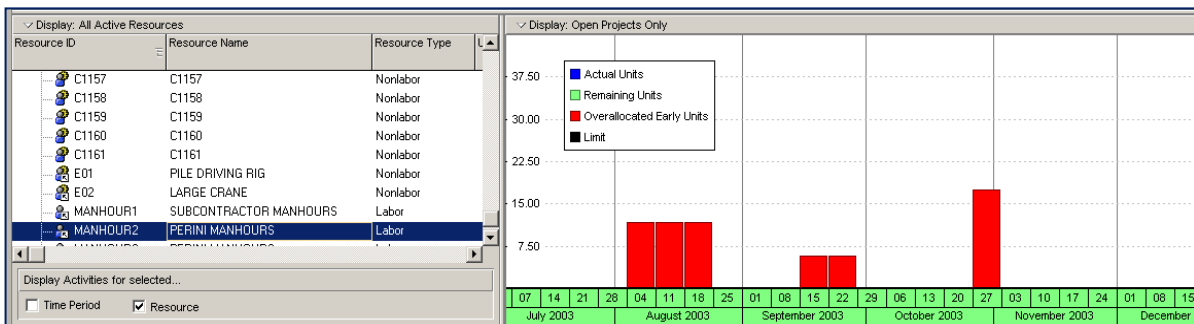

Steps:

In the **Layout Options** bar, click **Show on Bottom, Resource Usage Profile**.

Introduction to Critical Path Method Scheduling using Primavera P6.1 Client for Construction

Calculating Production Rates

	Actual (Original) Days	Square Meters Placed	SQM per Day	Square Meters Total	Square Meters Remaining	Days Left (calculated)	Days Left (Schedule)	Difference
MSE J	7.0 (5.0)	57.78	11.56	63.0	5.22	0.28	0.5	0.21
MSE A	45.0 (15.0)	1363.79	30.31	1669.8	306.11	10.10	10.0	(0.10)
MSE F	19.50 (10.0)	250.71	12.86	568.2	317.49	17.27	10.00	(7.27)
MSE G	35.00 (15.0)	1030.83	29.45	1032.2	0.0	0.0	0.0	0.0
Total**	183.50	3336.65	18.18	6149.42	2724.9	149.83	65.50	(83.04)

= Activity in progress
 = Activity finished

** = includes data from all MSE walls

Production Rate is measuring the actual work being done in an activity to forecast whether the planned duration will be sufficient to complete the activity in time and if not, to make the necessary adjustments to ensure its timely completion. It provides a glimpse of the immediate future so that proper adjustments can be made before the projected delay impacts the schedule.

Using the exhibit above taken for CEES (CPS) Inspector Reports, item MSE J has an Original Duration of 7 days to finish a 63.0 square meters of the MSE wall. Using the metrics from the Inspector Reports, the Actual Duration is now up to 5 days and has covered 57.78 square meter of the wall which is equal to 11.56 square meters per day. 5.22 square meters are remaining and at its current pace, it will be finished in 0.28 day with .50 day remaining in its planned duration. Therefore, we can say that with its production rate, work for item MSE J is just little bit ahead of its schedule.

Compare that to item MSE A, which at its current pace, has 10.10 calculated days left while having 10.0 days left in its planned duration. We can say that this one is slightly delayed of schedule with its current production rate.

Introduction to Critical Path Method Scheduling using Primavera P6.1 Client for Construction

Lesson 9: Resource Analysis

Review Questions

1. What are the different types of **Resource**?
2. NYSDOT contracts normally do not require **Resource Loading**. Under what scenarios does the Department require Resource Loading in their projects?
3. According to NYSDOT specification, what are the **Resource Loading Requirements** for a **Type2** project?
4. How do you display the **Resource Usage Profile** layout?
5. In Primavera, when should you create a new **resource**? How?

**Introduction to Critical Path Method Scheduling
using Primavera P6.1 Client for Construction**

Lesson 10:

Optimizing the NYSDOT Project Plan

Objectives

**This lesson explains the steps for optimizing a project plan.
At the completion of this lesson, you will be able to:**

- **Define project management's *Triple Constraints* and how they impact each other**
- **Analyze project schedule dates and settings to identify a potential problem**
- **Explain the ways of shortening a project schedule**

Introduction to Critical Path Method Scheduling using Primavera P6.1 Client for Construction

Project Management's Triple Constraints

Once you have received the schedule from the contractor, verify that it meets the Statewide CPM Special specification including activities, dates and resource requirements. If a disconnect exists between the information in the project plan and the specifications, you will be able to identify the source of the problem and define a solution.

- Analyzing schedule activities and dates – Evaluate the schedule to ensure that activities are properly defined and that milestone and project dates are achieved.
- Analyzing resource allocation – Evaluate the resources to ensure that the proper allocations are made to achieve the project goals.

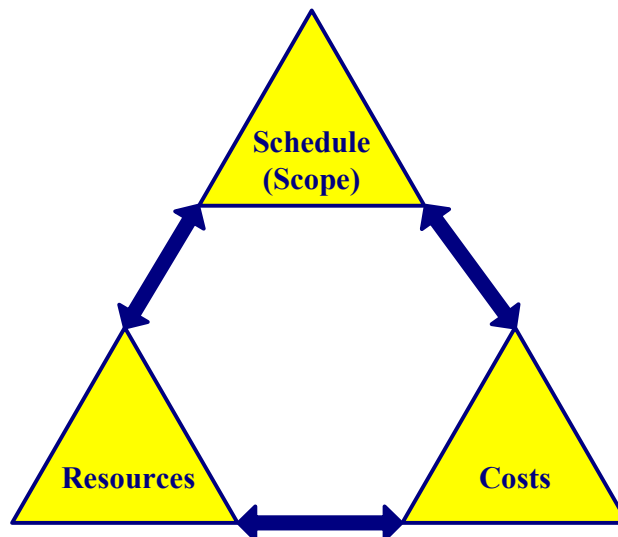

Introduction to Critical Path Method Scheduling using Primavera P6.1 Client for Construction

Analyzing Schedule Dates

The most important date in the schedule is the calculated project finish date. If the calculated finish date of the project is beyond the required project finish date, the project must be shortened. In addition, each deliverable in the project should be scheduled to finish by the dates imposed by the contract.

Steps for analysis:

- Compare the calculated (forecast) finish to the Must Finish By date.
- Work in the What-If Schedule
- Focus on the Critical Path (Longest Path).
- Shorten the project.

Note: The contract Completion Date has been entered in the *Must Finish By* date.

Comparing forecast Finish date to Must Finish By date

The screenshot displays the Primavera P6.1 Client interface. The 'Schedule Dates' tab is active, showing the following fields:

Field	Value
Project Planned Start	20-Mar-08 00:00
Must Finish By	31-Dec-11 17:00
Data Date	31-Jul-08 00:00
Forecast Finish	28-Dec-11 17:00
Actual Start	20-Mar-08 00:00
Actual Finish	

The 'Anticipated Dates' tab is also visible, showing:

Field	Value
Anticipated Start	
Anticipated Finish	

Red circles highlight the 'Must Finish By' date (31-Dec-11 17:00) and the 'Forecast Finish' date (28-Dec-11 17:00) in the 'Schedule Dates' tab.

Steps:

1. In the **Directory Bar**, click the **Projects** button.
2. Open your project.
3. In **Project Details**, click the **Dates** tab.

Introduction to Critical Path Method Scheduling using Primavera P6.1 Client for Construction

Focusing On the Critical Path (Longest Path) Activities

If the project is coming in late (showing negative total float), the project must be shortened to meet the contract date. To achieve this, you should focus on the Critical Path activities. These are the activities that will bring in the Finish date to comply with the contract. Modifying non-critical path activities will not help.

The critical path (longest path) activities are the longest continuous path of activities through a project that determines the project finish date. If you adjust a critical path activity, this should adjust the project finish.

The screenshot shows the 'Settings' dialog box in Primavera P6.1, specifically the 'Project Settings' tab. The dialog is divided into three main sections: 'Summarized Data', 'Project Settings', and 'Define Critical Activities'.
- **Summarized Data:** Includes a checkbox for 'Contains Summarized Data Only', a text field for 'Last Summarized On', a dropdown for 'Summarize to WBS Level', and radio buttons for 'High level resource planning' and 'Detail activity resource assignments'.
- **Project Settings:** Includes a text field for 'Character for separating code fields for the WBS tree', a dropdown for 'Fiscal year begins on the 1st day of' (set to 'January'), and radio buttons for 'Project baseline' (selected) and 'User's primary baseline'.
- **Define Critical Activities:** Includes radio buttons for 'Total Float less than or equal to' (with a value of '0') and 'Longest Path' (selected).

Steps:

1. In the **Directory Bar**, click the **Projects** button.
2. Open your project.
3. In **Project Details**, click the **Settings** tab.

Introduction to Critical Path Method Scheduling using Primavera P6.1 Client for Construction

Shortening the Project

If the schedule analysis leads you to conclude that the contract Completion Date cannot be met, you need to have the contractor concentrate his efforts on shortening the schedule. Several methods can help you accomplish this goal.

- ***Refine duration estimates.***
 - Assign additional resources to reduce activity durations.
- ***Modify activity relationships where feasible to have work activities, or work packages, run concurrently instead of sequentially***
- ***Consider (when appropriate) modifying contract requirements such as allowing night-time work, Work Zone Traffic Control limitations, etc.***
- ***Consider (when appropriate) removing contract work, and potentially including it in a Uncompleted Work Agreement***
- ***Change calendar assignments***
 - Assign critical path activities to a calendar with a longer workweek, longer workday or multiple shifts
 - Assign critical path activities to a calendar with a shorter seasonal shutdown period

Introduction to Critical Path Method Scheduling using Primavera P6.1 Client for Construction

Lesson 10: Optimizing the NYSDOT Project Plan

Review Questions

1. Explain the relationship behind **Scope, Resources** and **Cost**.
2. Explain the different ways to shorten a project using CPM.
3. In Primavera, how do you know when a project is coming in late?
4. How do you define the project's critical activities to "**Longest Path**"?
5. According to NYSDOT specification, where should the "**Must Finish By**" date be found?

Introduction to Critical Path Method Scheduling using Primavera P6.1 Client for Construction

Lesson 11:

Baselining the Project Plan

Objectives

**In this lesson, you will understand the term “baselining”.
At the completion of this lesson, you will be able to:**

- **Define the functionalities of a baseline**
- **Create and assign a baseline**
- **Review layouts using baseline and current project files**

Introduction to Critical Path Method Scheduling using Primavera P6.1 Client for Construction

What is a Baseline?

A baseline is a copy of a project schedule. It is a “snapshot” of an approved project schedule. It can be the first approved schedule or a later monthly schedule update. You can compare a baseline to the current project to evaluate progress and track cost, schedule and performance. Before updating a schedule for the first time, the contractor will submit a “Baseline Progress Schedule @Award” in a Critical Path Method (CPM) format for the Engineer’s review and acceptance.”

When the contractor submits schedule updates, the previous update will be used as a baseline for contemporaneous schedule analysis.

Baseline functionality in Primavera enables you to:

- Save an unlimited number of baselines per project.
- Designate one project baseline and up to ten user baselines at a time for comparison to the current project.
- Assign a baseline type to categorize a baseline. Examples include Baseline Progress Schedule@Award, Monthly Progress Schedule submissions, Recovery Schedule, etc.

Introduction to Critical Path Method Scheduling using Primavera P6.1 Client for Construction

Creating a Baseline

A baseline can be created by:

- Copying the currently opened project, or
- Converting another project into a baseline.

When a baseline is created, a project must be selected to associate with it. Baselines can be assigned only to open projects. All open projects are displayed in the Maintain Baselines dialog box. **(Note: Only admin staff can perform this function for you. Send an email to: CPMSchedulingSection@dot.state.ny.us)**

Steps:

1. Open your project. In the **Project** menu, click **Maintain Baselines**.

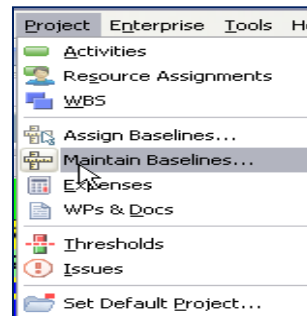

2. Click **Add**. Select **“Convert another project to a new baseline of the current project.”**
3. Click **OK**.

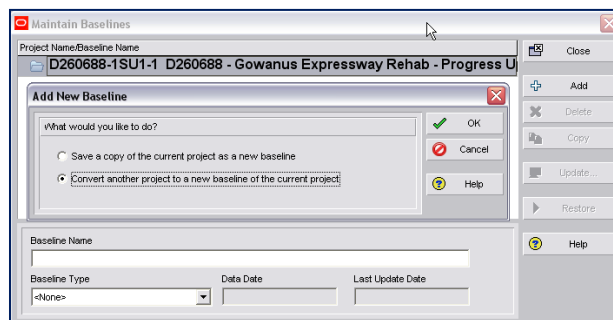

4. Select the project to be used as baseline. Click the **Select**  button.

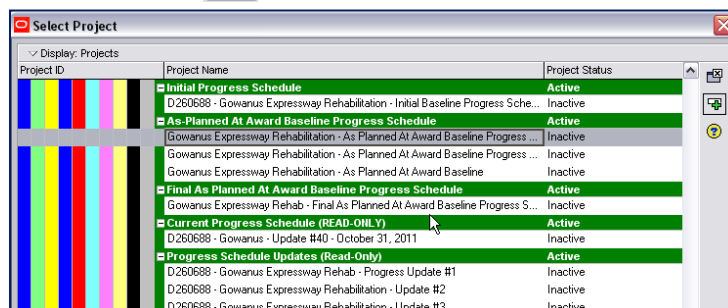

Introduction to Critical Path Method Scheduling using Primavera P6.1 Client for Construction

Assigning a Baseline

Use the *Assign Baselines* dialog box to choose a project baseline and/or user baseline for the project. If no baseline is designated as active, the current project plan is used as the baseline.

- Project baseline is the baseline selected by the project manager for the project.
 - Used for schedule, resource, and cost comparison.
 - Controlled by the security privilege *Maintain Project Baselines*.
- User baseline assignments are user-specific.
 - Used for schedule comparison only.
 - Each user can choose a different baseline for comparison to the current project.

Steps:

1. In the **Projects** menu, click **Assign Baselines**.

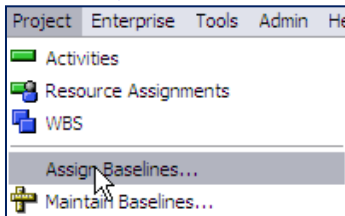

2. Select the baseline project for **Project Baseline** field. Click **OK**.

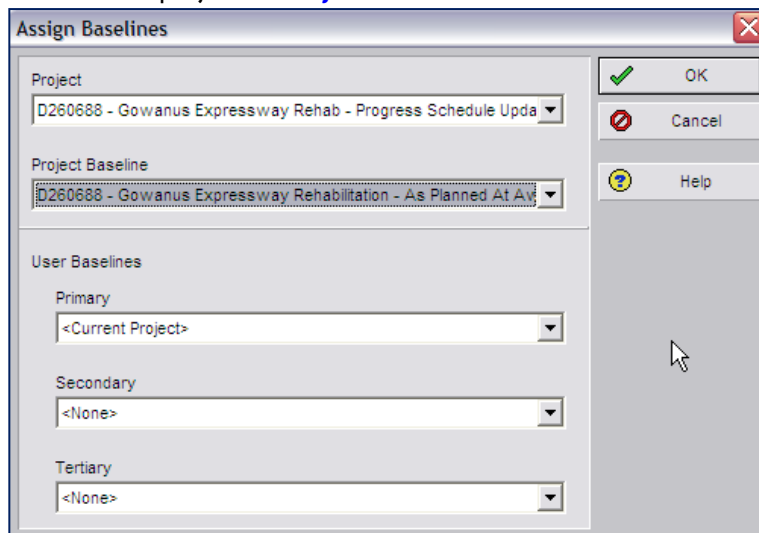

3. On the **Directory Bar**, click the **Activity** button.
4. Click **the Layout Bar** and open **Current vs Baseline Schedule Analysis** Layout.

Introduction to Critical Path Method Scheduling using Primavera P6.1 Client for Construction

Project Execution and Control

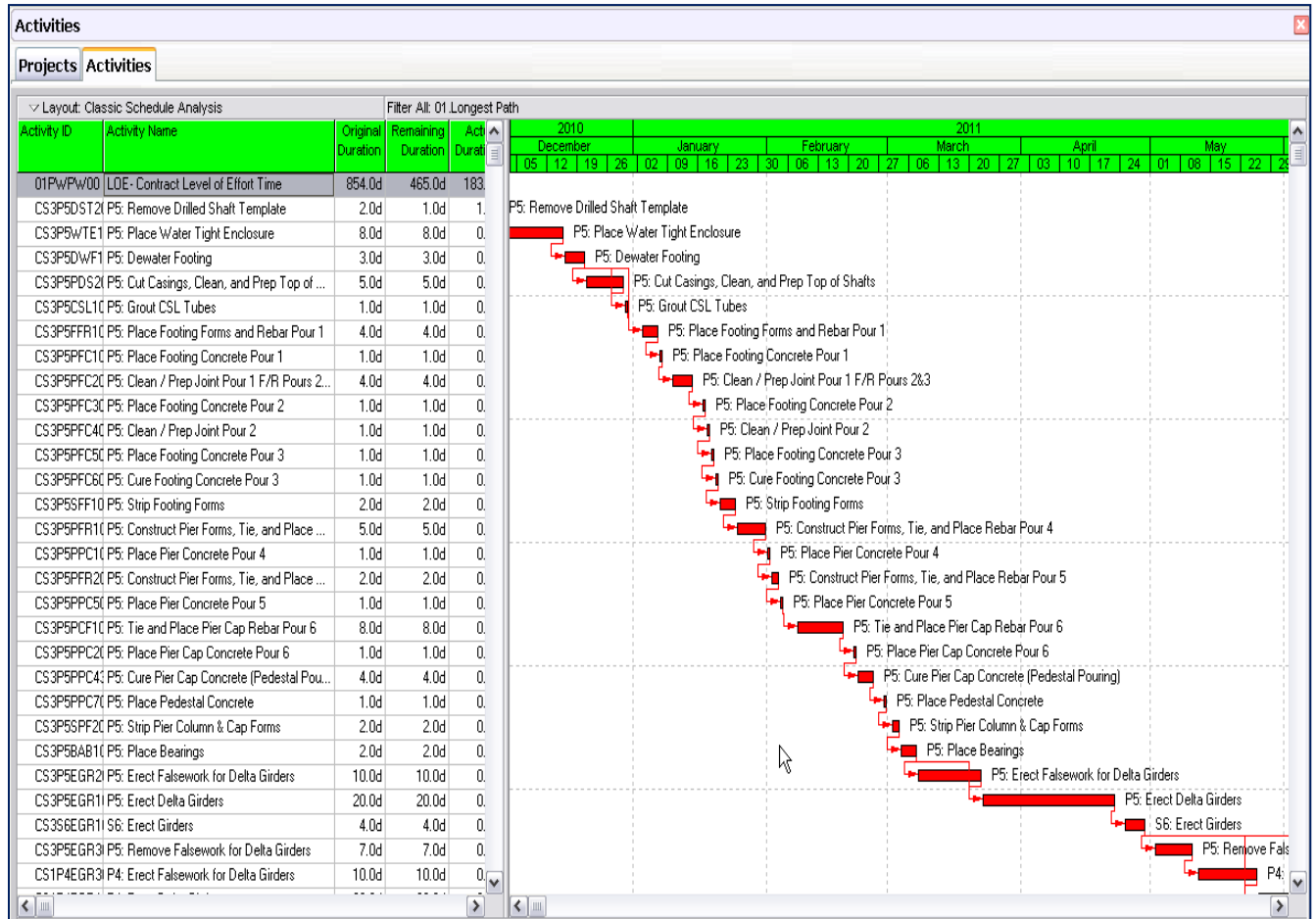

In this screenshot, you can see the comparison between the *Longest Path* of the current schedule (in Red) against the baseline schedule (in Yellow). In this case, you can see a slight shift in the activity bars.

Introduction to Critical Path Method Scheduling using Primavera P6.1 Client for Construction

Lesson 11: Baselining the Project Plan

Review Questions

1. What is a “**baseline**”?
2. What are the functions or uses of a **baseline**?
3. In Primavera, what **Activity Layout** is useful for examining baseline and current project files? Why?
4. Why is it recommended to compare the baseline and the current project files on a monthly basis?
5. What information can the Gantt Chart provide when using the **Current vs Baseline Schedule Analysis** layout?

Introduction to Critical Path Method Scheduling using Primavera P6.1 Client for Construction

Lesson 12:

Monthly Progress Schedule Submissions

Objectives

In this lesson, you will learn the monthly submittal review process. At the completion of this lesson, you will be able to:

- **Understand each step specified in the review process**
- **Run Claim Digger to compare projects' performance**
- **Review Claim Digger logs to identify project issues**

Excerpt from 4. Monthly Progress Schedule Submission, b, g:

- b) **Subsequent Monthly Progress Schedule Submissions** - On a monthly basis, the Contractor shall submit a copy of the current Progress Schedule that includes all Progress Schedule Revisions and Progress Schedule Updates to reflect the actual and planned prosecution and progress of the contract work. Progress Schedule Updates shall reflect the status of activities that have commenced or have been completed, including the following items: (a) actual dates in activity Actual Start and Actual Finish columns as appropriate; (b) actual Remaining Duration for activities commenced and not complete; and (c) actual activity Suspend or Resume dates for activities commenced and not complete. Progress Schedule Revisions reflect modifications made to activities in the current project baseline schedule in any of the following items: (a) activity Original Duration; (b) changes in logic connections between activities; (c) changes in Constraints; (d) changes to Activity Descriptions; (e) activity additions or deletions; (f) changes in Activity Code assignments; (g) changes in activity Resource assignments; and (h) changes in Calendar assignments. All "Out of Sequence" activities noted in the scheduling log shall be corrected to reflect the current construction operations. When preparing a formal submission of the progress schedule, the Contractor shall make a copy of the current Progress Schedule and name it according to the file naming convention provided by the Department in Table 1.

Introduction to Critical Path Method Scheduling using Primavera P6.1 Client for Construction

- g) **Schedule Submission Method** - The Contractor shall submit the schedule to the Engineer electronically for review and acceptance. The filename shall conform to the requirements of Table 1. The Project Scheduler can change the Project ID and Name through the WBS at the top node, as they do not have privileges to edit data through the Project Details tab. The Contractor's submission shall be documented by an E-mail to the Engineer, with a copy to CPMSchedulingSection@dot.state.ny.us and all appropriate project participants, that the project schedule on the network is ready for review. The Contractor's E-mail to the Engineer shall also consist of the following:
- i) The subject of the E-mail shall include the Region #, contract D number, the Project Name, the Progress Schedule's ProjectID, and construction company name. (i.e. – Region 8, D260000, Rehabilitation of Main Street viaduct, D260000-1UD2, ABC Contractors)
 - ii) The E-mail message shall include the name of the EIC, the current anticipated Finish date of the last activity in the project schedule, a statement as to how that date compares to the current Contract Completion Date, and the name of the Area Construction Supervisor.
 - iii) Electronic files of all Narrative Reports and required attachments associated with the schedule shall be submitted by the Contractor in Adobe Acrobat format.

Excerpt from Paragraph (E.2. Progress Schedule Review and Analysis):

2. Schedule Analysis Method.

Events, actions, and progress that cause delays or gains to the Progress Schedule will be analyzed solely by the "Contemporaneous Period Analysis" method.

The Contemporaneous Period Analysis evaluates delays or gains in the period in which it occurred. The analysis period for the purpose of these provisions shall be the period covered in each regular progress update to the schedule, as they coincide with contract payments to the Contractor.

Introduction to Critical Path Method Scheduling using Primavera P6.1 Client for Construction

Submittal Review Process

- Contractor submits updated schedule.
 - Moves the data date to the current reporting period.
 - Enters activity progress.
 - Reports resource use to date.
- NYSDOT Main Office Admin staff copies the project and notifies project review team by email.
- DOT project team reviews updated schedule. Uses Chapter VI of the CPM Scheduling Manual.
- Verify correct Data Date, “Must Finish By” date and that scheduling options are consistent with last submission.
- Review Schedule Log.
- Send request to CPMSchedulingSection@dot.state.ny.us to assign previous approved schedule as a baseline to the current schedule submission.
- Run Claim Digger and analyze report.
- Monitor project progress with reports and layouts. Project team ensures Contractor’s schedule has correct activity Actual Start dates and Actual Finish dates, and Remaining Durations that are consistent with the Inspector’s Report for that work period.
- Determine whether project objectives are being met.
 - Will the project finish on time or are interim milestones being met on time?
 - Are the key deliverable completion dates shifting?
 - Does contractor have adequate resources on the project?
 - Are there unauthorized changes, such as logic, durations, calendars, etc.?

Introduction to Critical Path Method Scheduling using Primavera P6.1 Client for Construction

Excerpt from Paragraph 4.d (Monthly Progress Schedule Submission):

d) Monthly Progress Schedule Narrative - For each Monthly Progress Schedule submission, the Contractor shall submit a narrative in Microsoft Word, or Adobe Acrobat format that includes, but is not limited to: (The narrative may be an annotated copy of the Claim Digger Report that includes the information below.)

- i) The contract D number, project name, project location, and name of Prime Contractor.
- ii) Actual contract Award Date, current contract Completion Date, and scheduled completion of all project work.
- iii) Any contract Interim Milestone dates (I/D, B-Clock, LD, etc), and scheduled Start and Finish dates for those Milestone activities.
- iv) List all activities on the Critical Path (include Activity ID's and Activity Descriptions) where work is currently being delayed, and for each such activity provide detailed information including:
 - the events that caused the delay.
 - the party(s) responsible for the delay event(s).
 - the number of days the activity has been delayed (negative float).
 - the activities in the construction schedule affected by the events.
 - the reasonable steps needed to minimize the impact of the delay, and which party needs to take the action(s).
- v) List any other problems experienced during this Progress Schedule submission period, the party responsible for the problems, and the Contractor's intentions to resolve the problems.
- vi) List all activities for procurement of long lead time materials that are behind schedule and the reason(s) why.
- vii) For major work items describe the differences between the actual work performed and the work planned for the period as represented in the preceding Progress Schedule submission, including explanations for the deviations.
- viii) For all suspended work activities that could otherwise logically be progressed, identify the responsible party prohibiting the progression of the work, as well as the detailed reasons why.
- ix) Description of any changes to the critical path since the last Monthly Progress Schedule submission and the impacts of such changes.
 - x) Change to State Owned Float and/or Contractor Owned Float based on changes to the critical path.
 - xi) List of all added or deleted activities included in this Monthly Progress Schedule submission, and the reason(s) for and the impact(s) of such changes.
 - xii) List all changes in activity Original Durations, the justification for such change(s), and the impact(s) of such changes.
 - xiii) List all changes in relationships between activities included in this Progress Schedule submission, and the reason(s) for and the impact(s) of such changes.
- xiv) List any addition or deletion of activity or project constraints, and the reason(s) for and the impact(s) of such changes.
- xv) List all changes to the project calendars, and the reason(s) for and the impact(s) of such changes.
- xvi) The major work elements, as defined in the WBS, to be accomplished during the next monthly work period.

Introduction to Critical Path Method Scheduling using Primavera P6.1 Client for Construction

Continued:

- xvii) Any potential problems that are anticipated for the next monthly work period and the proposed solutions to such problems. Identify potential problems or risks that either the Department or Contractor may be potentially responsible for. Explain what action the responsible party (i.e. - Department or Contractor) needs to take and the date by which time the action needs to be taken to avoid the problem.
- xviii) Any planned acceleration of activities that the Contractor anticipates to undertake within the next monthly work period that either the Department directed, or that the Contractor believes is necessary.
- xix) The following appendix in Adobe Acrobat PDF file format, formatted to fit ANSI Size D paper (610 mm x 914 mm) (24 inch x 36 inch) paper, shall be included with the narrative.
- APPENDIX 1 – A listing of all work activities as of the data date, using the Classic Schedule Layout, sorted by Early Start Date, Total Float in increasing order, showing the Activity ID, Activity Description, Original Duration, Remaining Duration, Total Float, Early Start date, Early Finish date, Start date, Finish date, and Calendar ID. The grouping of activities shall be by Area, Stage, WZTC Phase, and Type of Work. The Gantt Chart shall clearly indicate the project critical (longest) path. Graphical representations shall be shown at a suitable scale to be legible and readable.
- The following appendices in Adobe Acrobat PDF file format, formatted to fit 216 mm x 279 mm size (8.5 inch x 11 inch) paper, shall be included with the narrative.
- APPENDIX 2 – A complete Scheduling/Leveling Report (SCHEDLOG.TXT file generated by the Department's Primavera scheduling software application) which includes the Schedule Settings, Statistics, Errors, Warnings, Scheduling/Leveling Results, Exceptions, Activities with unsatisfied constraints, Activities with unsatisfied relationships, and Activities with external dates. The statistics shall include, # of Activities, # of Activities Not Started, # of Activities In Progress, # of Activities Completed, # of Activity Relationships, and # of Activities with Constraints. Total number of activities on the critical path, percent complete, activities without predecessors, activities without successors, and activities out of sequence.
 - APPENDIX 3 – Claim Digger Report (generated by the Primavera software application) providing a comparison between this Progress Schedule submission and the previous Progress Schedule submission.

Introduction to Critical Path Method Scheduling using Primavera P6.1 Client for Construction

Excerpt from K. Progress Schedule Updates and Weekly Status Reports:

- 1) The Contractor shall perform a Progress Schedule Update on a minimum of a weekly basis, and every fourth schedule update period shall be consistent with monthly contract payment period.
- 2) The Contractor shall generate a Weekly Status Report after performing the Progress Schedule Update and Scheduling the project with a Data Date of day the schedule was updated, and submit it to the Engineer within one (1) State Business Day of the Data Date for that update period. The Weekly Status Report shall be generated using the activity Layout named Weekly Status Report, with activities grouped by the WBS, and using the standard default filter named Longest Path. The Gantt Chart shall clearly indicate the project critical (longest) path. Graphical representations shall be shown at a suitable scale to be legible and readable.
- 3) During any time periods within the contract that special time-related contract provisions are in effect, including B-Clock periods or Incentive/Disincentive Periods, the Engineer may require more frequent Progress Schedule Updates and/or Progress Schedule Status Reports.

METHOD OF MEASUREMENT:

The quantity shall be measured for payment on a Lump Sum basis.

The minimum lump sum bid for this item shall be the unit price shown in the itemized proposal.

Failure of the Contractor to bid at least the minimum amount will result in the Department adjusting the Contractor's bid to include the minimum bid amount for this item.

BASIS OF PAYMENT:

The lump sum price bid for CPM Progress Schedules shall include all labor, material, equipment, and incidentals, required to complete the work.

Progress payments will be made as follows:

- A. A total of twenty-five (25) percent will be paid upon achieving all of the following:
 1. Attendance at the Preconstruction Schedule Meeting
 2. Acceptance of the Baseline Progress Schedule @ Award.
 3. Acceptance of the Final Baseline Progress Schedule @ Award.
 4. Acceptance of the List of Submittals.
- B. A total of forty five (45) percent will be paid for acceptance of Monthly Progress Schedule submissions, acceptance of any necessary Time Impact Analysis, and acceptance of any necessary Recovery Schedules.

Progress payments for this item will be calculated by multiplying the Daily Payment Amount by the calendar days in the estimate period, less any deductions for unsatisfactory CPM Progress Schedules, Time Impact Analysis, or Recovery Schedules. The Daily Payment amount will be calculated by taking 45 percent of the total item cost divided by the number of calendar days in the contract duration as designated in the proposal, without regard to any extension of time.

- C. A total of twenty five (25) percent will be paid for submittal of Weekly Status Reports, participation in progress meetings, and submittal of Look-Ahead Schedules.
Progress payments for this item will be calculated by multiplying the Bi-weekly Payment amount by the number of Bi-weekly periods (1 or 2) in the estimate period, less any deductions for unsatisfactory Status Reports or Look-Ahead Schedules, or non attendance at progress meetings. The Bi-weekly Payment amount will be calculated by taking 25 percent of the total item cost divided by the number of bi-weekly periods in the contract duration as designated in the proposal, without regard to any extension of time
- D. A total of five (5) percent will be paid upon acceptance of the As-Built Progress Schedule.

Introduction to Critical Path Method Scheduling using Primavera P6.1 Client for Construction

Continued:

Following notification by the Engineer that there are deficiencies in compliance with the specification requirements, as described in paragraph E.1, with the submittal of any Progress Schedule no payment will be made under CPM Progress Schedules for each calendar day during which those deficiencies continue to exist. The amount of such calendar day non-payment will be the Daily Payment Amount as calculated above multiplied by the number of days there are deficiencies in compliance with the specification requirements.

Non-refundable liquidated damages may be assessed for each subsequent calendar day or part thereof that a cited deficiency resulting in non-payment is not corrected or is permitted to recur. Non-refundable liquidated damages will be assessed at the rate equal to four times the Daily Payment Amount as calculated above.

In the event the contract completion date is extended, no additional payment will be made for CPM Progress Schedules for Non-compensable Delays. If the contract completion date is extended due to a Compensable Delay than payment for maintaining and submitting additional CPM Progress Schedules, Weekly Status Reports, and weekly Look-Ahead Schedules shall be equal to the Daily Payment Amount as calculated above multiplied by the number of calendar days the contract is extended plus the Bi-weekly Payment Amount multiplied by the number of bi-weekly periods the contract is extended.

Payment will be made under:

Item No.	Item	Pay Unit
639.1022 01	CPM (Critical Path Method) Progress Schedule – Type 2	LS

Introduction to Critical Path Method Scheduling using Primavera P6.1 Client for Construction

Claim Digger

Claim Digger is a utility that compares two projects – a revised project and a base project – and creates a report on the differences between the project's schedules, including:

- Items added
- Items deleted
- Changed values

Key Claim Digger functionality:

- Report is created in either HTML, CSV, or text format. HTML format suggested.
- Select the baseline and revised projects to be used for comparison.
- Comparison options can be turned on/off based on your needs.

Launching Claim Digger:

Steps:

- I. Highlight the project files to be compared , right-click and choose **Summarize**.

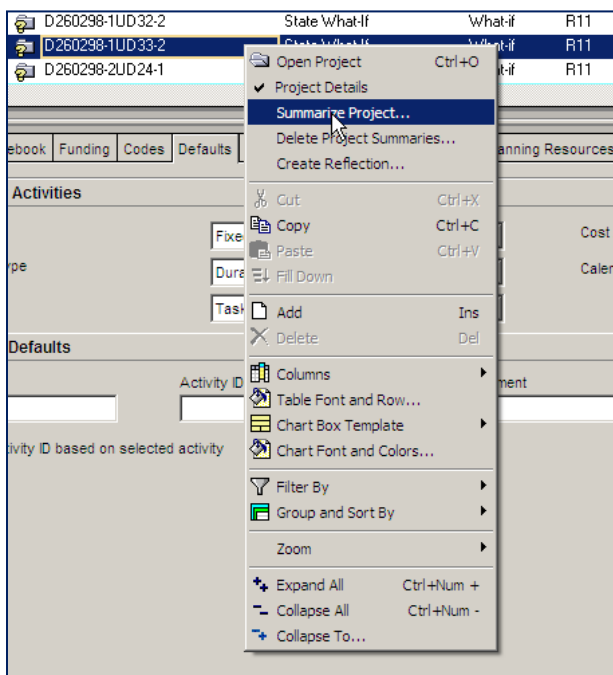

Introduction to Critical Path Method Scheduling using Primavera P6.1 Client for Construction

2. In the **Tools** menu, click **Claim Digger** to launch the utility.

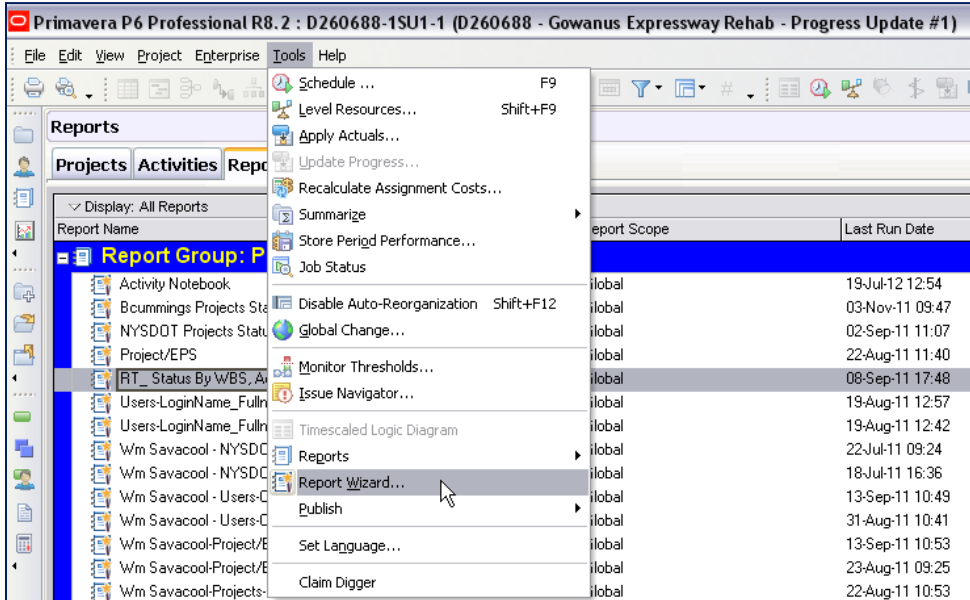

3. At **Primavera Schedule Comparison** window, click the box under “**Select original project or baseline.**”
Click the **Ellipsis** box  to select the baseline project.

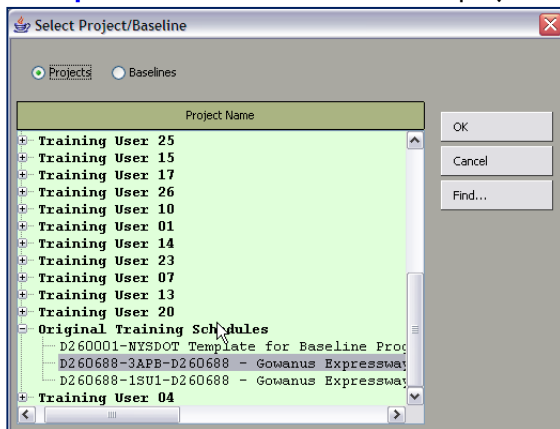

Introduction to Critical Path Method Scheduling using Primavera P6.1 Client for Construction

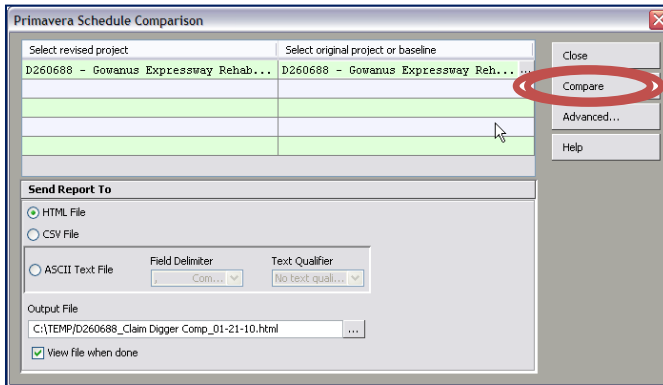

3. Click the **Advanced** button and select the **Advanced Project Comparison Options**. Click **OK**.

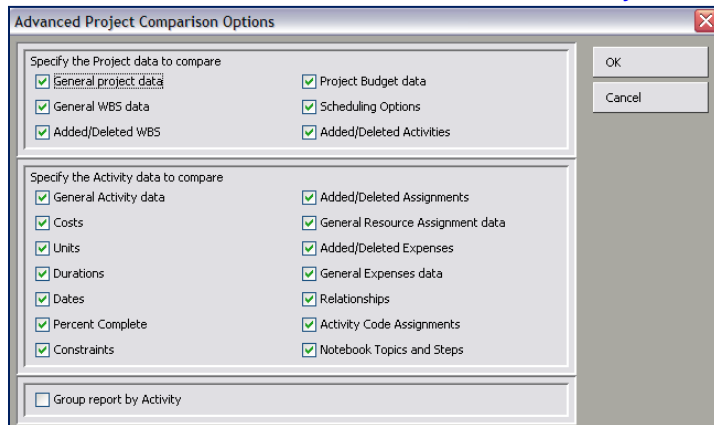

4. At **Send Report To**, select **HTML File** or **CSV File**. Never select ASCII Text File.
5. Enter the path of the output file by clicking the **Ellipsis** box .
6. Select **“View file when done”** by clicking the box.
7. Click the **Compare** button.

Note: When HTML file is chosen, the output can be edited and saved in Word and Adobe PDF format. When CSV file is chosen, the output file can be edited and saved in Excel format.

Introduction to Critical Path Method Scheduling using Primavera P6.1 Client for Construction

Schedule Analysis Checklist – See Chapter VI of the CPM Scheduling Manual

Items to look for in the electronic schedule:

- Recalculate the schedule (F-9) (in What-If area) and verify the correct data date
- “Must Finish By” date in the Project details equals the contract completion date.
- “Open End” listing report in the “Schedule Statistics Report”
- “Constraints” listing report in the “Schedule Statistics Report”
 - You may also run filters “Has Start Constraint” or “Has Finish Constraint”
Note that constraints will reduce float.
- “Longest Path” filter
- Utilize other standard layouts and filters for an efficient review
 - Layouts:
 - Baseline Schedule Review
 - Classic Schedule Analysis
 - Classic Schedule Layout
 - Current vs Baseline Schedule Analysis
 - Monthly Progress Schedule Submission
 - 2 Week Lookahead
 - Filters:
 - Has Finish/Has Start Constraints
 - Longest Path
 - Milestone
 - DD -7 days (Actual Start or Actual Finish)
 - (RESPONSIBLE PARTY) = DOT
 - (RESPONSIBLE PARTY) = Prime Contractor
- Create filter for NYSDOT responsibilities
 - Evaluate activities, durations, and relationships
Are activities Actual Start and Actual Finish dates consistent with Daily Diary reports?
 - Are the NYSDOT activities “Front Loaded”?
 - What NYSDOT activities are on the Longest Path?

Introduction to Critical Path Method Scheduling using Primavera P6.1 Client for Construction

Verify that the Department is not unduly exposed for delay claims

- Convert last update to the Primary Baseline
- Review “Claim Digger” report for unauthorized changes from the last update
 - Were actual dates removed from the last update
 - Were logic ties changed
 - Were durations changed
 - May be done to support a delay claim
- In Primavera, use the “**Current vs Baseline Schedule Analysis**” layout to graphically see changes

Introduction to Critical Path Method Scheduling using Primavera P6.1 Client for Construction

Analyzing Performance

Analyzing the contractor's electronic schedule file is an important part of your project responsibilities. It is generally regarded that an owner's "acceptance" of a Progress Schedule is seen as a tacit approval, unless the owner's documented review comments back to the Contractor indicate it is rejected or accepted as noted citing deficiencies that need to be corrected.

A printed schedule plot/report may not display key performance indicators for the project which may be affecting the schedule to the detriment of the Department. It is important that the Department's review of the Progress Schedule consist of an analysis of the electronic schedule file used to generate the printed report/plot.

The report below is an example of what could be submitted on a paper report showing the schedule performance for the project that has a contract end date of July 2, 2003. The dates shown on the report would indicate conformance to the contract date.

LIE/CIP #D258437-NYS DOT #28 (37W8)

29-May-07 21:43

NYS DOT-Schedule Status Report

WBS						
Activity ID	Activity Name	Original Duration	Remaining Duration	Schedule % Complete	Scheduled Start	Scheduled Finish
LIE/CIP #D258437-NYS DOT #28 (37W8)						
L90135	ESTABLISH TURF LIE ML EB S. SHLDR EHB TO CLV	3	3	0%	28-Apr-03	30-Apr-03
L98500	CONSTRUCT NEW PARK TRAIL MULCH COVER LIE SE QUAD	15	15	0%	28-Apr-03	16-May-03
L98500	CONSTRUCT ASPH TRAIL (TULIP) @ DEMO'D EXT RAMP W	15	15	0%	28-Apr-03	16-May-03
L99120	WOOD CHIP MULCH VINE BEHIND BARRIER N. SHL EH/CL	2	2	0%	29-Apr-03	30-Apr-03
Z99980	PUNCH LIST WORK - LIE/CIP PROJECT #D258437	15	15	0%	17-May-03	31-May-03
C99980	DEMOBILIZATION/FINAL CLEANUP - CONTRACT D258437	30	30	0%	01-Jun-03	30-Jun-03
OL50-255	REMOVE REMAINING SEDIMENT CONTROL DEVICES, RAPR	2	2	0%	25-Jun-03	26-Jun-03
OL50-999	REVISED ALLEY POND RESTORATION COMPLETE	1	1	0%	30-Jun-03	30-Jun-03
Z99990	ACCEPTANCE OF PROJECT - LIE/CIP #D258437	1	1	0%	01-Jul-03	01-Jul-03



The project's contractual finish date is July 2, 2003

Introduction to Critical Path Method Scheduling using Primavera P6.1 Client for Construction

Analyzing Performance (cont.)

The second example report shows the same project data, but with additional data that shows a more accurate project status. In this extreme example, the current finish date is June 28, 2004.

LIE/CIP #D258437-NYSDOT #28 (37W8)

29-May-07 22:12

NYSDOT-Schedule Status Report -All Dates

WBS		Original Duration	Remaining Duration	Schedule Complete	Late Start	Start	Late Finish	Finish	Total Float
LIE/CIP #D258437-NYSDOT #28 (37W8)									
L90135	ESTABLISH TURF LIE ML EB S. SHLDR EHB TO CLV	3	3	0%	28-Apr-03	30-Sep-03	30-Apr-03	02-Oct-03	-22
L96500	CONSTRUCT NEW PARK TRAIL MULCH COVER LIE SE QUAD	15	15	0%	28-Apr-03	23-Apr-04	16-May-03	13-May-04	-151
L98500	CONSTRUCT ASPH TRAIL (TULIP) @ DEMO'D EXT RAMP W	15	15	0%	28-Apr-03	20-Apr-04	16-May-03	10-May-04	-148
L99120	WOOD CHIP MULCH VINE BEHIND BARRIER N. SHL EH/CL	2	2	0%	29-Apr-03	22-Mar-04	30-Apr-03	23-Mar-04	-47
Z99980	PUNCH LIST WORK - LIE/CIP PROJECT #D258437	15	15	0%	17-May-03	14-May-04	31-May-03	28-May-04	-363
C99980	DEMOBILIZATION/FINAL CLEANUP - CONTRACT D258437	30	30	0%	01-Jun-03	29-May-04	30-Jun-03	27-Jun-04	-363
OL50-255	REMOVE REMAINING SEDIMENT CONTROL DEVICES, RAPR	2	2	0%	25-Jun-03	01-Apr-04	26-Jun-03	02-Apr-04	-125
OL50-999	REVISED ALLEY POND RESTORATION COMPLETE	1	1	0%	30-Jun-03	05-Apr-04	30-Jun-03	05-Apr-04	-125
Z99990	ACCEPTANCE OF PROJECT - LIE/CIP #D258437	1	1	0%	01-Jul-03	28-Jun-04	01-Jul-03	28-Jun-04	-363

(c) Primavera Systems, Inc.

Page 1 of 1

The project's contractual finish date is July 2, 2003

Introduction to Critical Path Method Scheduling using Primavera P6.1 Client for Construction

Lesson 12: Monthly Progress Schedule Submissions

Review Questions

1. Why is it important to review the **Schedule Log** on a monthly basis?
2. What are things to look out for in the **Schedule Log**?
3. What are the ways to determine whether the project objectives are being met?
4. What can you find in a **Claim Digger** report?
5. How can we best utilize the functions of **Claim Digger**?
6. Define **Contemporaneous Period Analysis**.

Introduction to Critical Path Method Scheduling using Primavera P6.1 Client for Construction

Lesson 13:

Reporting Performance

Objectives

In this lesson, you will look at the different methods of generating reports in Primavera. At the completion of this lesson, you will be able to:

- Compare the different reporting tools available
- Run each printing option for generating reports
- Create and print a customized report

Introduction to Critical Path Method Scheduling using Primavera P6.1 Client for Construction

Printing Existing Reports:

There are many methods to distribute schedule, resource, and cost performance information to the project team, including:

- Printed Layouts (cut and paste from the layout window)
- Printed reports from the Report Wizard
- Printed reports from Report tools.
- Primavera web applications

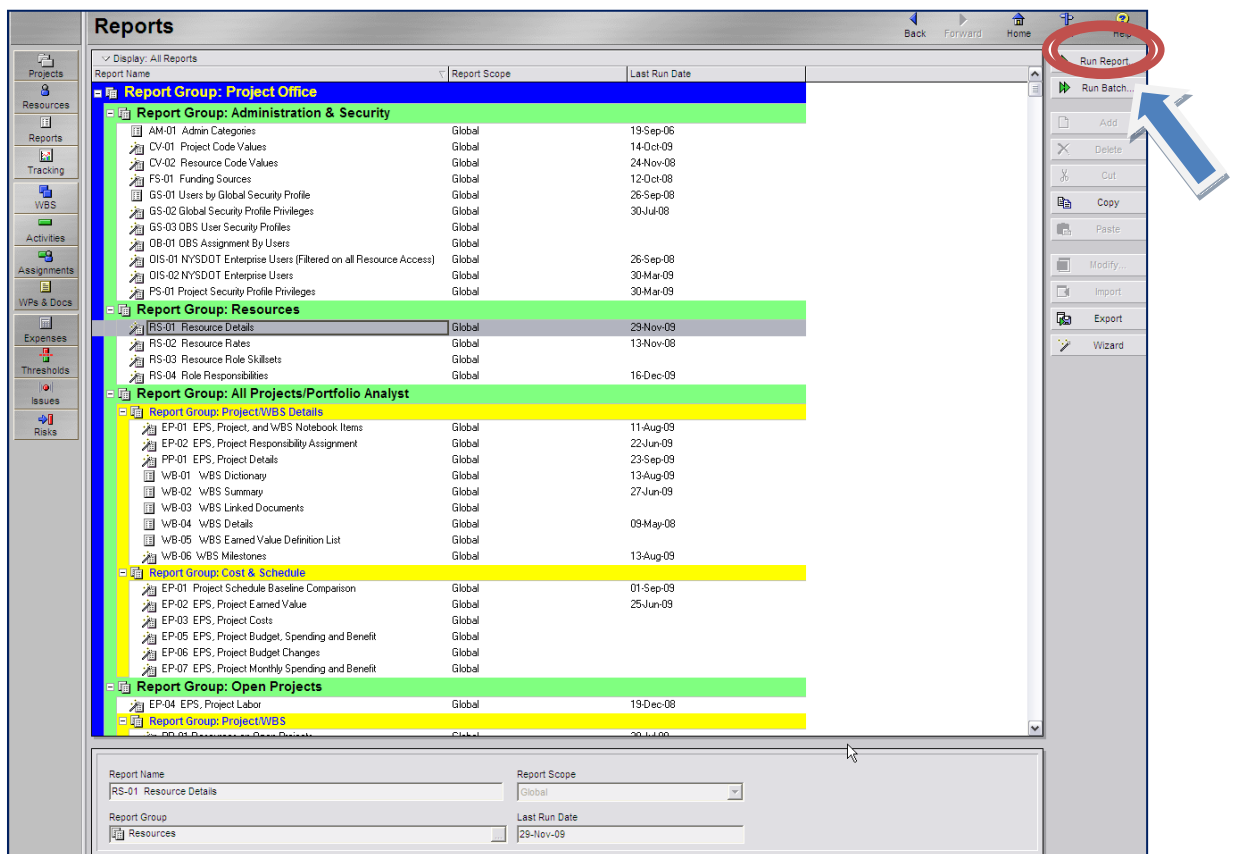

Steps:

1. From the **Directory Bar**, click **Reports**.
2. Select report.
3. In the **Command Bar**, click **Run Report**.

Introduction to Critical Path Method Scheduling using Primavera P6.1 Client for Construction

Creating New Reports using Report Wizard

1. On the **Menu Bar**, click **Tools**. Select and click **Report Wizard**.

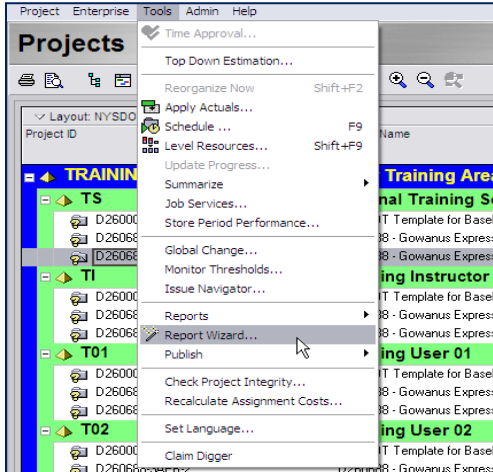

4. On the **Create or Modify Report** window, select **New Report** and click **Next**.
5. On **Select Subject Area** window, choose the subject area for the report. Select **Activities** and click **Next**.

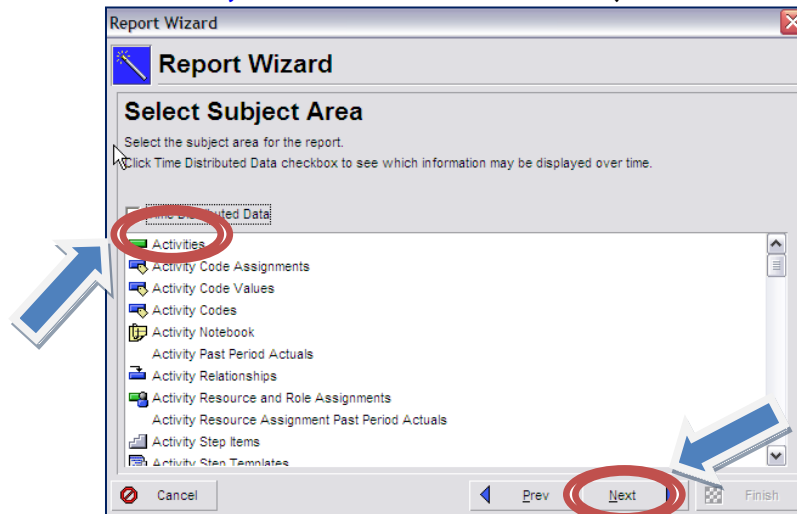

6. On **Select Additional Subject Areas**, select **Activity Steps**, **Predecessors** and **Successors**. Click **Next**.

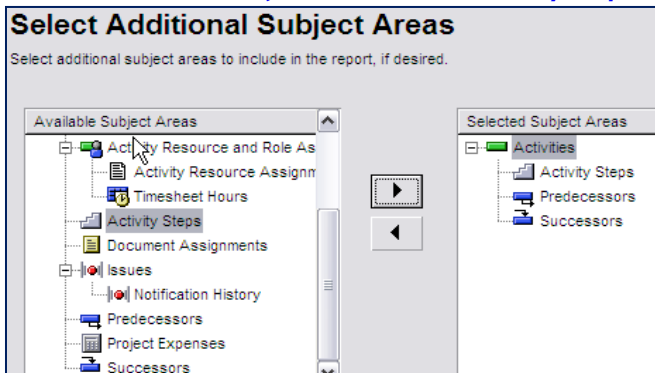

Introduction to Critical Path Method Scheduling using Primavera P6.1 Client for Construction

7. On **Configure Selected Subject Areas**, set the **Columns**, **Group & Sorts** and **Filter** configurations by clicking on each of the buttons. After setting configurations, click **Next**.

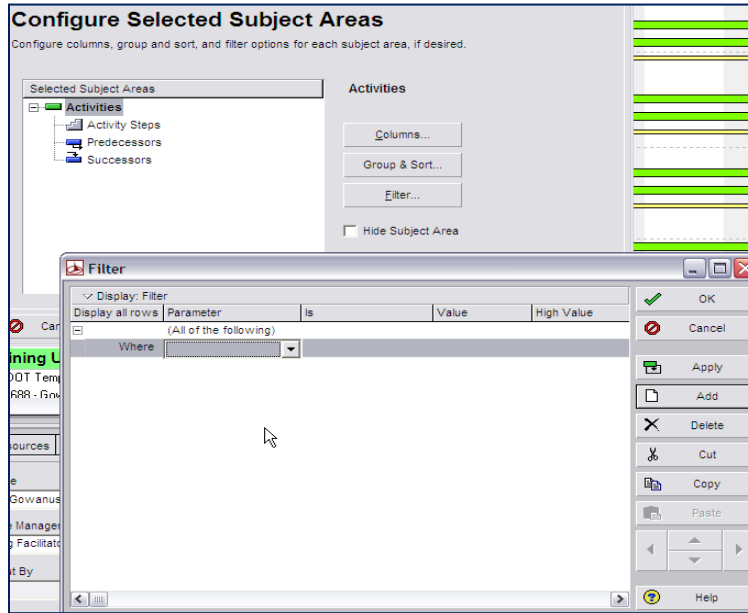

8. Add a title to your report. Click **Next**.

9. Click **Run Report**.

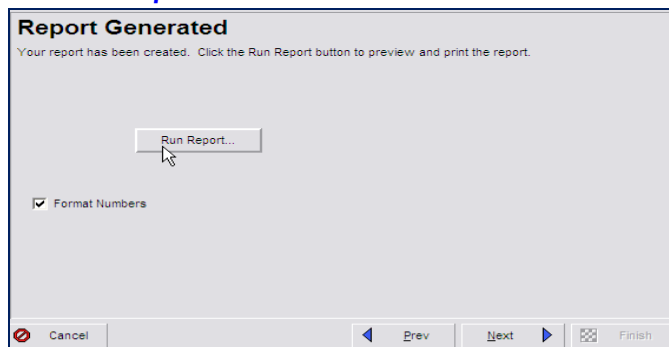

10. Determine where you want to send the report. Click **OK**. Click **Next**. Click **Finished**.

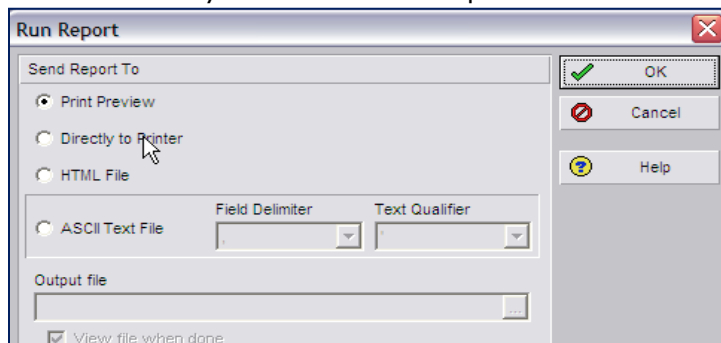

Introduction to Critical Path Method Scheduling using Primavera P6.1 Client for Construction

Lesson 13: Reporting Performance

Review Questions

1. What are the different methods for generating reports in Primavera?
2. What method is best to use when customizing reports?
3. What are the different configuration options that can be used in customizing reports in Primavera?
4. Why does NYSDOT's new specification require contractors to develop and maintain their schedules on NYSDOT network servers only?
5. Why is it in the best interests of the contractors to comply with this specification?

Introduction to Critical Path Method Scheduling using Primavera P6.1 Client for Construction

Appendix:

NYSDOT CPM Specification

NYSDOT has implemented an updated Statewide CPM (Critical Path Method) Special Specification. The new specification will provide NYSDOT a common platform for enterprise level program management and standards for project level management. NYSDOT project field office staff will coordinate with the contractors to establish detailed CPM project schedules that will be closely monitored to track performance, reduce delays and claims, and aid in the successful delivery of contracts.

Following is the Statewide Special CPM Specification:

Item 639.1022 01 – CPM (CRITICAL PATH METHOD) PROGRESS SCHEDULES – TYPE 2

DESCRIPTION

This work shall consist of preparing, maintaining and submitting a Progress Schedule using the Critical Path Method on Primavera P6 software, or newer release, which demonstrates complete fulfillment of all work shown in the contract documents. All work to prepare, and maintain the CPM Progress Schedule shall be performed using the scheduling software application provided by the Department on network servers and accessed through the Internet with Department provided user accounts. **The Contractor shall regularly revise and update the Progress Schedule, and use it in planning, coordinating, and performing all work.** Schedule activities shall accurately depict the entire scope of work to be performed to complete the project including, but not limited to, all work to be performed by the Contractor, subcontractors, fabricators, suppliers, consultants, the Department, and others, contributing to the project.

DEFINITIONS

Activity - A discrete, identifiable task or event that usually has an expected duration, has a definable Start Date and/or Finish Date, and can be used to plan, schedule, and monitor a project.

Activity, Controlling - The first incomplete activity on the critical path.

Activity, Critical - An activity on the critical path.

Actual Start date- At the activity level, the Actual Start date represents the point in time that a meaningful work actually started on an activity.

Actual Finish date - At the activity level, the Actual Finish date represents the point in time that work actually ended on an activity (**Note: in some applications areas, the activity is considered “finished” when work is “substantially complete.”**); at the project level, the Actual Finish date represents the point in time that the Contractor completes all work on the project and it is accepted by the Engineer.

Backward Pass – Calculation of the late start and late finish dates for each activity, based on the start or finish dates of successor activities as well as the duration of the activity itself. Also known as the second pass.

Baseline Progress Schedule @ Award- The Progress Schedule submitted by the Contractor and accepted by the Department that shows the plan to complete the construction contract work. The Baseline Progress Schedule @ Award represents the Contractor’s plan at the time of contract Award for completing the Project.

Bid Date – The date the contract is let and there is an announcement by the Department of an apparent low bidder.

Completion Date, Contract - The date specified in the Contract for completion of the project or a revised date resulting from properly executed time extensions.

Completion Date, Scheduled - The date forecasted by the Progress Schedule for the completion of the Project.

Constraint - A schedule restriction imposed on the Start or Finish date(s) of an activity that modifies or overrides an activity’s relationships.

Progress Schedule Delay - An event, action, or other factor that delays the critical path of the Progress Schedule and extends the time needed for completion of the construction project.

Item 639.1022 01 – CPM (CRITICAL PATH METHOD) PROGRESS SCHEDULES – TYPE 2

Contemporaneous Period Analysis Method – A technique for evaluating schedule delays or time savings. The analysis period for the purpose of these provisions shall be the period covered in each regular progress update to the schedule, as they coincide with contract payments to the Contractor.

Contractor Owned Float Activity – The activity that documents time saved on the critical path by actions of the Contractor. It is the last activity prior to the contract Completion Date milestone activity.

Contractor Start Work date – The actual date the Contractor starts field work of a contract pay item, which is entered as a Start milestone activity in the schedule. Contractually no work may start until after the contract is awarded by the *Office of State Comptroller*, and the Contractor has received a Notice to Proceed from the *Contract Management Bureau*. Should the Contractor choose to show activities in the schedule that reflects their plan of work prior to the contract award, the Department does not incur any liability and such work being performed between the bid date and the contract award date shall be considered at risk work.

Critical Path – In the Progress Schedule the critical activities shall be those activities being on the longest path. In a project network diagram, the series of activities which determines the earliest completion of the project. The critical path will generally change from time to time as activities are completed ahead of or behind schedule.

Critical Path Method (CPM) – A network analysis technique used to predict project duration by analyzing which sequence of activities (which path) has the least amount of scheduling flexibility (the least amount of float). A scheduling technique utilizing activities, durations, and interrelationships/dependencies (logic), such that all activities are interrelated with logic ties from the beginning of the project to the completion of the project. Early dates are calculated by means of a forward pass using a specified start date. Late dates are calculated by means of a backward pass starting from a specified completion date (usually the forward pass' calculated project early finish date).

Data Date – The date entered in the Project Details, in the Dates tab, which is used as the starting point to calculate the schedule. For the Baseline Progress Schedule @ Award submission the Data Date shall be the contract Award Date; for Monthly Progress Schedule submissions, the Data Date shall be the date up to which the Contractor is reporting progress (generally the last working day for the corresponding contract payment period, and for Weekly Status Reports the Data Date shall be the Saturday of that week). If the Contractor submits a Baseline Progress Schedule @ Bid submission, the Data date shall be the date of the schedule submission to the Engineer and not prior to the bid date. Everything occurring earlier than the data date is "as-built" and everything on or after the data date is "planned."

Deliverable – Any measurable, tangible, verifiable outcome, result, or item that must be produced to complete a project or part of a project. Often used more narrowly in reference to an external deliverable, which is a deliverable that is subject to approval by the Department.

Duration, Original - The original estimated number of working days (not including holidays or other non-working periods) in which the work task associated with the activity is expected to be performed. (The number of calendar days may be different based on the calendar assigned to the activity.) For certain activities such as concrete curing, or others approved by the Engineer, the calendar shall reflect no non-working days.

Duration, Remaining - The estimated time, expressed in working days (not including holidays or other non-working periods), needed to complete an activity that has started but has not finished.

Early Dates – The earliest date an activity can start or finish based upon logic and durations. Calculated by the software application when scheduling the project.

Item 639.1022 01 – CPM (CRITICAL PATH METHOD) PROGRESS SCHEDULES – TYPE 2

Early Completion Date(s) - A progress schedule shall be considered to have an early completion date when the schedule submitted by the Contractor indicates an anticipated completion date(s) that is/are earlier than the specified contract milestone date(s), which includes:

- (i) the Scheduled Completion Date appearing as the “Finish” date in the Project Details, in the Dates tab, is earlier than the current contract Completion Date as of the Data Date of the progress Schedule.
- (ii) the Finish Date of any interim Milestone activity, that describes an item of work in the contract with a required completion date, is earlier than the date specified in the contract as of the Data Date of the progress Schedule. This includes, but is not limited to, B-Clock activities, activities subject to Incentive/Disincentive provisions, activities subject to specific Liquidated Damages provisions, and Lane Rental activities.

Enterprise Project Management Database (EPMD) – The Department’s database of construction project Progress Schedules.

Final Baseline Progress Schedule @ Award - The original plan against which the Contractor’s progress is measured. The Final Baseline Progress Schedule @ Award represents the original plan at the award of the contract, of what is expected to happen. Once the Final Baseline Progress Schedule @ Award is accepted by the Engineer it is saved and used as a basis to compare against Progress Schedules Updates.

Float Suppression - Utilization of zero free float constraints which allows an activity to start as late as possible by using all its' available free float. This technique allows activities to appear more critical than if the activity's total float was based on early dates. Assigning zero free float prevents true sharing of total float between Department and the Contractor. Examples of float suppression techniques include preferential sequencing (arranging the critical path through activities more susceptible to State caused delay), extending activities durations, incorporating several activities that actually require a half day or less of effort with Finish to Start relationships but showing each as full day durations where one activity would be appropriate, manipulating calendars, or any other such methodology.

Float, Free - The amount an activity can slip without delaying the immediate successor activities. Free Float is the property of an activity and not the network path.

Float, Total - The amount of time an activity (or chain of activities) can be delayed from its early start without delaying the contract completion date. Float is a mathematical calculation and can change as the project progresses and changes are made to the project plan. Total Float is calculated and reported for each activity in a network, however, Total Float is an attribute of a network path and not associated with any one specific activity along that path.

Fragnet – A subdivision of a project network diagram usually representing some portion of the project.

Global data – Data classified by Primavera software as Global, including Project Codes, Global Activity Codes, Global Calendars, Resource Calendars, Global Filters, Resources, Global Reports, User Defined Fields and Unit of Measure. Global Activity Codes are used to organize project activities across the enterprise project structure according to specific categories, such as the Code Value STG1 for Stage 1 under the Global Activity Code STAGE. Whereas Project Activity Codes are used to organize project activities for a specific project only.

Initial Baseline Progress Schedule – The Contractor’s schedule prior to submittal to the Engineer of the Baseline Progress Schedule @ Award, that reflects the Contractor’s plan to perform work during the time period while the full Baseline Progress Schedule is being developed, reviewed and accepted.

Key Plans - Key Plans are graphic representations made by the Contractor’s project Scheduler on paper copies of the appropriate contract plan sheets that reflect the Contractor’s planned breakdown of the project

Item 639.1022 01 – CPM (CRITICAL PATH METHOD) PROGRESS SCHEDULES – TYPE 2

for scheduling purposes to efficiently communicate the Contractor's activity coding scheme to State scheduling staff. The key plans prepared by the Contractor shall clearly define the boundaries of the work for each designated Area, the operations contained in various Stages of work, and work in the Work Zone Traffic Control (WZTC) Phases. The alphanumeric codes on the key plans shall match the code values for the activity code "Area", "Stage", and "WZTC Phase" in the Progress Schedule.

Late Dates – "Drop dead dates". The latest an activity can start or finish without delaying the day of completion. Calculated by the computer during the backward pass.

Longest Path - The sequence of activities through the Progress Schedule network that establishes the Scheduled Completion Date

Look-Ahead Schedule – Commonly a one or two week time segment generated from the accepted Progress Schedule that forecasts the work planned for the one or two week period following the Data Date, and includes any major materials to be delivered and any lane closings or anticipated shifts in WZTC.

Milestone – An activity with zero duration that typically represents a significant event, usually the beginning and end of the project, milestones set forth in the contract proposal, construction stages, a major work package, or the contract interim time-related clauses.

Narrative Report - A descriptive report submitted with each Progress Schedule. The required contents of this report are set forth in this specification.

Open End - The condition that exists when an activity has either no predecessor or no successor, or when an activity's only predecessor relationship is a finish-to-finish relationship or only successor relationship is a start-to-start relationship.

Predecessor - An activity that is defined by Schedule logic to precede another activity. A predecessor may control the Start Date or Finish Date of its successor.

Progress Schedule – A general Primavera P6 Schedule as defined by this Specification.

Progress Schedule Update – Changes to the Progress Schedule that reflect the status of activities that have commenced or have been completed, including the following items: (a) Actual Start date and or Actual Finish date as appropriate; (b) Remaining Duration for activities commenced and not complete; and (c) Suspend or Resume dates for activities commenced and not complete.

Progress Schedule Revision – Revisions to the Progress Schedule ensure it accurately reflects the current means and methods of how the project is anticipated to progress, including modifications made to any of the following items: (a) changes in logic connections between activities; (b) changes in constraints; (c) changes to activity descriptions; (d) activity additions or deletions; (e) changes in activity code assignments; (f) changes in activity resource assignments; and (g) changes in calendar assignments.

Project Scheduler – The person that is responsible for developing and maintaining the Progress Schedule.

Projects Planned Start Date – The date entered in the Project Details, in the Dates tab, that reflects the Contractor's planned start of work (based on contract requirements, and reasonable expectation for a Notice to Proceed) at the time the bid was submitted to the Department.

Projects Must Finish By Date – A date constraint entered in the Project Details, in the Dates tab, that reflects the Contract Completion Date set in the Contract Documents or through a formal contract extension of time.

Item 639.1022 01 – CPM (CRITICAL PATH METHOD) PROGRESS SCHEDULES – TYPE 2

Recovery Schedule – A schedule depicting the plan for recovery of significant time lost on the project. This separate CPM schedule submission shall provide the resolution and include appropriate changes in network logic, calendar adjustments, or resource assignments.

Relationships - The interdependence among activities. Relationships link an activity to its predecessors and successors. Relationships are defined as:

Finish to Start - The successor activity can start only when the current activity finishes.

Finish to Finish – The finish of the successor activity depends on the finish of the current activity.

Start to Start – The start of the successor activity depends on the start of the current activity.

Start to Finish – The successor activity cannot finish until the current activity starts.

Resources, Contract Pay Item – Contract Pay Item resources shall be identified as a Material resource type. When required, Contract Pay Item resources are developed for each Pay Item in the contract, with the Resource ID matching the contract Pay Item and the Resource Name matching the description of the contract Pay Item.

Resources, Equipment – Equipment resources shall be identified as a Nonlabor resource type. A unique identifier shall be used in the Resource Name or Resource Notes to distinguish this piece of equipment from a similar make and model of equipment used on the project.

Resources, Labor – Labor resources shall be identified as a Labor resource type. Labor Resources shall identify resources that encompass direct labor at the Crew level.

Scheduling/Leveling Report – The report generated by the software application when a user “Schedules” the project. It documents the settings used when scheduling the project, along with project statistics, errors/warnings, scheduling/leveling results, exceptions, etc.

State Business Days – Monday through Friday, with the exception of State Holidays.

State Owned Float Activity – The activity that documents time saved on the critical path by actions of the State. It is the last activity prior to the Completion Date activity and any Contractor Owned Float activity.

Substantial Completion - the day, determined by the Engineer, when all of the following have occurred:

1. The public (including vehicles and pedestrians) has full and unrestricted use and benefit of the facilities both from the operational and safety standpoint, and
2. All safety features are installed and fully functional, including, but not limited to, illumination, signing, striping, barrier, guard rail, impact attenuators, delineators, and all other safety appurtenances, and
3. Only minor incidental work, replacement of temporary substitute facilities or correction or repair remains for the Physical Completion of the Contract, and
4. The Contractor and Engineer mutually agree that all work remaining will be performed without lane closures, trail/sidewalk closures, or further delays, disruption, or impediment to the public.

Successor - An activity that is defined by Schedule logic to succeed another activity. The Start Date or Finish Date of a successor may be controlled by its predecessor.

Time Impact Analysis - A technique to demonstrate the comparison of a time impact of a Progress Schedule revision prior to a change in the Contract work, against the current accepted Progress Schedule. **Also known as a “What-If” analysis.**

Weekly Status Report – The report generated weekly from the updated Progress Schedule in an electronic Adobe Acrobat PDF format that reflects a Data Date for that Progress Schedule Update period. The report

Item 639.1022 01 – CPM (CRITICAL PATH METHOD) PROGRESS SCHEDULES – TYPE 2

shall be formatted to fit ANSI Size D paper (610 mm x 914 mm) (24 inch x 36 inch), listing all work activities from the data date to contract completion, using the NYSDOT Status Report Layout, sorted by Early Start Date, Total Float in increasing order, showing the Activity ID, Activity Description, Original Duration, Remaining Duration, Total Float, Early Start date, Early Finish date, Start date, Finish date and Calendar ID.

Work Breakdown Structure (WBS) - A deliverable-oriented grouping of project elements, which organizes and defines the total scope of the project. Each descending level represents an increasingly detailed definition of project components or work packages.

Work Package - A deliverable at the lowest level of the work breakdown structure. A work package contains activities.

Working Day - A Working Day is a calendar day scheduled for active prosecution of the work.

CONSTRUCTION DETAILS

A. Project Scheduler:

The Contractor shall designate an individual, entitled the Project Scheduler, who will develop and maintain the construction progress schedule. The Project Scheduler shall be present at the Preconstruction Schedule Meeting, prepared to discuss, in detail, the proposed sequence of work and methods of operation, and how that information will be communicated through the Progress Schedule. The Project Scheduler shall attend all meetings, or receive meeting minutes that outline schedule related issues of those meetings, which may affect the CPM schedule, including but not limited to those between the Contractor and their Subcontractors and between the Contractor and the Department. The Project Scheduler shall be knowledgeable of the status of all aspects of the work throughout the length of the Contract, including but not limited to: original contract work, additional work, new work, and changed conditions of work.

B. Scheduling Software:

The State will provide Primavera P6 software, or newer release, and computer system for use by the Engineer to review the schedules submitted by the Contractor. The Department has installed Primavera P6 software, or newer release, on internet accessible servers for use by the Department's construction inspection staff. Appropriate Department personnel, Consultants, and Contractors will also have access to these schedules on the Department's Enterprise Project Management Database (EPMD). The Department will determine the location to store the project schedule files on the EPMD, and will provide the Contractor the naming convention for all progress schedule submissions.

The Contractor shall submit Request for Access Forms to the Regional Construction Engineer for each proposed Primavera user to obtain the User ID's and Passwords for access to software and data on the Department's network servers. The form can be downloaded from the following web page <https://www.nysdot.gov/main/business-center/contractors/construction-division/primavera>, or can be provided by the Department's Construction Supervisor. These forms may submitted any time following the contract letting date and announcement by the Department that the Contractor is the apparent low bidder. The Department will process these requests and should generally provide the User ID's and Passwords within two weeks of receipt by the Regional Construction Engineer. Upon approval and authorization by the Regional Construction Engineer, required User ID's and passwords will be provided to the Contractor (for the Project Scheduler plus one other person) to obtain secure Internet access to the Primavera software and project schedule data. If the Contract is not awarded to this Contractor, the Contractor's access to this project will be removed. Department provided User Id's and Passwords are assigned to specific individuals and shall not be shared with any other users.

Item 639.1022 01 – CPM (CRITICAL PATH METHOD) PROGRESS SCHEDULES – TYPE 2

The Department will provide the Contractor either a Preliminary Construction Schedule or a project schedule template for the Contractor’s use in developing their CPM Progress Schedule. The Contractor shall develop, update, and revise the Progress Schedules using Primavera P6 software that has been loaded on the Department’s network servers and the Contractor shall store all Progress Schedule files on the Department’s network servers.

The Department will generally not “Import” or accept Progress Schedule files from any other computer system. However, the Department may consider a request to Import a Baseline Progress Schedule developed by the Contractor prior to the contract Letting Date using Primavera P6 that meets the requirements of this specification, if the request is made by the apparent low bidder to the Department within two weeks of the Letting Date with a copy of the file attached. The schedule file shall not contain any User Defined fields, all Calendars assigned to activities must be project level Calendars not Global or Resource Calendars, all Activity Codes shall be project level and not Global or EPS level Activity Codes, no Resources shall be assigned to activities, and no Project Codes shall be assigned.

Access rights within the Primavera network solution will be created and maintained by the Department. As this software is an enterprise application, the Department will be the sole entity to modify the EPS structure, the OBS Structure, Project Codes, Global Activity Codes, Global Calendars, User Defined Fields, Security Profiles, Admin Categories, and Admin Preferences.

Progress Schedules	1st Version	2nd Version	3rd Version
Initial Baseline Progress Schedule	D26####-1IB	D26####-2IB	D26####-3IB
Baseline Progress Schedule @ Award	D26####-1BPS	D26####-2BPS	D26####-3BPS
Final Baseline Progress Schedule @ Award	D26####-1FB	D26####-2FB	D26####-3FB
Month #1 Progress Schedule Submission	D26####-1SU1	D26####-2SU1	D26####-3SU1
Month #2 Progress Schedule Submission	D26####-1SU2	D26####-2SU2	D26####-3SU2
As-Built Progress Schedule (Last Progress Schedule)	D26####-1AB	D26####-2AB	D26####-3AB
1 st Time Impact Analysis	D26####-1TIA1	D26####-2TIA1	D26####-3TIA1
1 st Recovery Schedule	D26####-1RS1	D26####-2RS1	D26####-3RS1

Primavera software and schedule data on the Department’s EPMD will generally be available for the Contractor’s use at all times unless system maintenance (i.e. backups, upgrades, etc) is being performed. System maintenance will generally be conducted over short time periods between the hours of 10 PM – 6AM, Monday - Friday and on weekends. The Department does perform regular backup of data contained in the EPMD, and will make every effort to restore the latest historical copy of schedule submissions in the event of any data failure of the EPMD. The Contractor shall also be responsible for exporting copies of project progress schedules, recovery schedules, TIA schedules, after data modifications have been made as their backup of these submissions. In the event a Contractor’s authorized user cannot access the software from 6AM to 10PM Monday through Friday, the Contractor shall provide written notification to the Engineer.

Project schedules are developed from the Contractor’s knowledge of the project, and the means and methods represented in those schedules are based on the Contractor’s understanding of the contract documents, and the Contractor’s past experience, which are unique to the Contractor. Schedule activity data and logic are therefore the intellectual property of the Contractor and will not be made available to other Contractors. All other schedule data, and all Enterprise data residing on the network servers, are the sole property of the Department.

C. Preconstruction Schedule Meeting:

The Contractor shall contact the Regional Construction Engineer after notification they are the apparent low bidder, but no later than two (2) State Business Days following the notice of contract award to schedule a Preconstruction Schedule Meeting. The purpose of this meeting will be to discuss all essential matters

Item 639.1022 01 – CPM (CRITICAL PATH METHOD) PROGRESS SCHEDULES – TYPE 2

pertaining to the satisfactory scheduling of project activities, and to resolve any known questions regarding interpretation of the contract requirements for this work.

The Project Scheduler shall be prepared to discuss the following:

1. The proposed hierarchical Work Breakdown Structure (WBS) for the Progress Schedules. The Project Scheduler shall provide a paper copy at the meeting.
2. The proposed project calendars.
3. The proposed project activity codes, and various code values for each activity code. The Project Scheduler shall provide a paper copy at the meeting.
4. Specifics of any contract Time-Related Clauses (A+B Bidding, Incentive/Disincentive, Liquidated Damages, Lane Rental, etc.);
5. The Contractor's schedule methodology to be employed, proposed work sequence and any proposed deviations from the contract plans with respect to Staging or Work Zone Traffic Control phasing.
6. The Key Plans shall be provided at the meeting.
7. The factors that the Contractor determines to control the completion of the project and any milestone activity completion dates contained therein.
8. The Project Scheduler shall provide an outline for the content of the Narrative report for future Progress Schedule submissions.
9. Schedule submission protocol for Final Baseline Progress Schedule @ Award and Monthly Progress Schedule submissions.

The Engineer will be available to answer questions regarding scheduling, including: the availability of Department supplied electronic file(s) containing sample project schedule information, sample progress schedule narratives, Special Notes for CPM Scheduling, and required standard format for CPM Progress Schedules for contract work.

The Contractor shall schedule meetings as necessary with the Engineer to discuss schedule development and resolve schedule issues, until the Final Baseline Progress Schedule @ Award is accepted by the Engineer.

The Contractor is encouraged, but not required, to submit an Initial Baseline Progress Schedule that demonstrates a sample of how the Project Scheduler's proposed alphanumeric coding structure and the activity identification system for labeling work activities in the CPM progress schedule will conform to the detailed requirements of this specification. The review and comment by the Engineer of the sample schedule should assist the Project Scheduler in assuring the first submittal of the Baseline Progress Schedule @ Award will be in general conformance with the requirements of the specification and other contract requirements, and that major rework of the Baseline Progress Schedule @ Award will not be required. This submission shall reflect the Contractor's anticipated plan to complete the contract work in accordance with the contract documents, as envisioned by the Contractor at the time of contract bid. This submittal may be made anytime following notice to the Contractor that they are the anticipated low bidder on the contract. Critical items for this review should include but are not limited to: the proposed WBS for subsequent progress schedules; the proposed project Calendars; project Planned Start date; project Must Finish By date; major milestone activities (i.e. - Award, Notice to Proceed, Contract Completion); and between fifty to one hundred summary activities for the major work deliverables of the contract (i.e. - pave EB from STA x to STA y, construct roundabout 1, construct bridge xyz, etc) that have assigned Activity Ids, Activity Descriptions, Activity Durations, Predecessors, Successors, and Activity Relationships. These summary activities will be broken down into, or supplemented with, individual work activities for the baseline submission. If any Crew resources are included, the composition of the staffing (the number and titles of the various staff) shall be listed in the Notes tab of the Crew resource, and the composition of the crews shall be included in the narrative. To the extent practicable, the Initial Baseline Progress Schedule should include administrative and procurement activities to be accomplished during the contract; planned submittal, review, and approval dates

Item 639.1022 01 – CPM (CRITICAL PATH METHOD) PROGRESS SCHEDULES – TYPE 2

for shop drawings, working drawings, fabrication drawings, and contractor supplied plans, procedures, and specifications.

If the Contractor proposes deviations to the construction staging or Work Zone Traffic Control Plans shown on the contract documents, then the Contractor must present a second Baseline Progress Schedule submission that reflects these proposed changes.

Any submission of a Initial Baseline Progress Schedule should be accompanied by a written Narrative that provides details of the Calendar assignments of working days versus non-working days, outlines the sequence of planned operations to complete the project work, and provides the proposed Activity Codes and Code values to be assigned to activities in future submissions of project progress schedules. The Engineer will review the logic diagram, coding structure, activity identification system, and Narrative; and provide comments for required changes by the Project Scheduler for implementation in the submission of the Baseline Progress Schedule @ Award. The Engineer will provide written comments on major deficiencies within five (5) State Business Days of receipt.

The Department reviews Initial Baseline Progress Schedules solely for format, and will not consider any submission of an Initial Baseline Progress Schedule for approval as an Early Completion Schedule.

The Contractor shall schedule meetings as necessary with the Engineer to discuss schedule development and resolve schedule issues, until the Baseline Progress Schedule at Award is accepted by the Engineer.

As an Initial Baseline Progress Schedule is being reviewed solely for format, the Department will not consider any submission of an Initial Baseline Progress Schedule for approval as an Early Completion Schedule.

D. Progress Schedule:

1. General

In addition to the attributes of the Progress Schedule provisions as set forth in §108-01, the Contractor shall prepare, furnish, and maintain a computer-generated Progress Schedule using the Critical Path Method (CPM) utilizing Primavera scheduling software on the Department's network servers. The CPM Progress Schedule shall be prepared based on the principles defined by the latest issue of the Construction Planning & Scheduling Manual published by the Associated General Contractors of America, except where superseded by the contract documents such as the CPM Special Notes and this specification.

The Contractor and the Department shall use the Progress Schedule to manage the work, including but not limited to the activities of subcontractors, fabricators, the Department, other involved State agencies and authorities, other entities such as utilities and municipalities, and all other relevant parties involved with the project.

No work other than installation of the Engineer's Field Office, mobilization, procurement and administrative activities, installation of construction signs, installation of erosion and pollution protection, clearing and grubbing, field measurements, and survey and stakeout will be permitted to start until the Baseline Progress Schedule @ Award has been submitted to the Engineer, and the Engineer determines there are no deficiencies consistent with those identified in paragraph E.1.

The Contractor will be the sole entity allowed to physically modify the following data within the progress schedule: activity IDs; activity descriptions; activity durations; relationships between activities; successors and predecessors, actual start and actual finish dates of activities; planned start and planned finish dates of

Item 639.1022 01 – CPM (CRITICAL PATH METHOD) PROGRESS SCHEDULES – TYPE 2

activities; and activity resources (with the exception that activities assigned resources labeled to reflect Department personnel may be changed to reflect specific individuals, or job roles, within the Department).

The Department may modify certain data associated with the progress schedule to ensure conformance to the Department's Enterprise Project Management standard schedule format. This means that the Department may: create additional layouts, filters and reports; create and edit additional user defined custom data fields; assign Project Codes; add and assign additional project Activity Codes; add and assign additional Cost Account Codes; add and assign additional Resource Codes; enter data in Notebook tabs; modify calendar ID's (although not the calendar itself); etc; that do not alter the established activities or schedule logic of the Contractor. The Engineer shall communicate to the Project Scheduler the types and scope of changes planned to be made to the progress schedules prior to the implementation of those changes. The Contractor shall not delete or modify any schedule data entered by the Department without prior approval by the Engineer. The schedule data added by the Department shall be incorporated into future schedule submissions of the Contractor.

The Contractor shall develop the Progress Schedule using, to the maximum extent practicable, the Global Activity Codes (DOT GLOBAL) and Resources (NYSDOT Pay Item Resources) identified in the Department's Primavera enterprise solution. Any schedule "Layouts", "Filters" and "Report" formats that the Contractor develops for the various Progress Schedules submissions to the Engineer shall be saved and made available to all other users of the project schedule with a name that includes the contract D#.

The Department may make copies of the progress schedules to perform what-if type analysis, which may involve any type of modification to those copies of the schedules.

The purpose of the Progress Schedule shall be to:

- ensure adequate planning and staffing during execution of the work by the parties to the contract;
- ensure communication and coordination of activities among all affected parties;
- assist the Contractor and the Department in monitoring the progress of the work, and evaluating proposed changes to the contract and/or requests for additional time to project completion;
- establish a standard methodology for time adjustment analysis based on the principles of the Critical Path Method of scheduling, for use in time-related dispute resolution;
- determine appropriate extensions or reductions of Contract Time.

In scheduling and executing the work, the Contractor shall:

- a) Sequence the work commensurate with the Contractor's abilities, resources and the contract documents. The scheduling of activities is the responsibility of the Contractor.
- b) Ensure that Progress Schedules prepared by the Project Scheduler for submission to the Department are in compliance with the Contract. The intent should be that Schedule submissions and accompanying Narratives are timely, complete, accurate, and in compliance with the Contract.
- c) Communicate all Contract changes, and decisions or actions taken by the Contractor and all subcontractors, fabricators, etc, that effect the Progress Schedule to the Project Scheduler in a timely manner to allow appropriate development, maintenance, and update of the Progress Schedule.
- d) Include all work contained in the Contract and all work directed in writing by the Engineer. Work activities directed by the Engineer to be added to the Contract shall be included in the next Monthly Progress Schedule submission.
- e) Assure that Progress Schedule Updates reflect the actual dates that work activities started and completed in the field.
- f) Break a schedule activity into multiple activities to reflect a discontinuity in the work if a work activity is suspended in the field and restarted at a later date, and the break between when the work was suspended to when it was resumed is significant compared to the original activity duration.

Item 639.1022 01 – CPM (CRITICAL PATH METHOD) PROGRESS SCHEDULES – TYPE 2

- g) Ensure the Progress Schedule contains all work constraints and Milestones defined in the Contract.
- h) Schedule the work using such procedures and staging or phasing as required by the Contract. Work designated as part of separate stages may be performed concurrently with other stages where allowed by the Contract or where approved by the Department.

Failure by the Contractor to include any element of work required by the Contract in the accepted progress schedule does not relieve the Contractor from its responsibility to perform such work.

Errors or omissions on schedules shall not relieve the Contractor from finishing all work within the time limit specified for completion of the contract.

2. Baseline Progress Schedule @ Award

- a) The Contractor shall ensure the schedule accurately reflects the proposed approach to accomplish the work outlined in the Contract documents and conforms to all requirements of this specification.
- b) The schedule shall define a complete logical plan that can realistically be accomplished, to execute the work defined in the Contract.
- c) The schedule shall comply with the work constraints and milestones defined in the Contract as well as all other contractual terms and conditions. The schedule shall be consistent in all respects with the specific interim Time-Related Contract Provisions, and any order of work requirements of the contract documents. The schedule shall meet all interim milestone dates and shall not extend beyond the contract completion date. This submission shall reflect the Contractor's plan at the time of contract award, and prior to the start of any work. **No negative float is allowed in the Baseline Progress Schedule @ Award submission.**
- d) **Detailed Schedule Requirements - As a minimum, the Contractor shall address the following in the Baseline Progress Schedule:**
 - i) Defining Project details and defaults – Within the Dates tab, the “Planned Start” shall be either the Letting Date or the contract Award Date, the “Data Date” shall be the date of Contract Award, the “Must Finish By” date shall be the contract Completion Date. Within the Settings tab, define the Critical Activities as the “Longest Path”. The Project Scheduler role does not have security privileges to change this data in the project Details tab, so requests for changes to this data needs to be forwarded to the CPMSchedulingSection@dot.state.ny.us; include in your request the contract Dnumber and the ProjectID.
 - ii) Sufficient activities shall be included to assure that there is adequate planning for the entire project. The appropriate number of activities will be largely dependent upon the nature, size, and complexity of the project. In addition to all site construction activities, network activities shall include: activities necessary to depict the procurement/submittal process including shop drawings and sample submittals; the fabrication and delivery of key and long-lead procurement elements; testing of materials, plants, and equipment; settlement or surcharge periods activities; sampling and testing period activities; cure periods; activities related to temporary structures or systems; activities assigned to subcontractors, fabricators, or suppliers; erection and removal of falsework and shoring; major traffic stage switches; activities assigned to the Department and other involved State agencies and authorities, including final inspection; activities to perform punch list work; and activities assigned to other entities such as utilities, municipalities, County government/agencies, and other adjacent contractors. The schedule shall indicate intended submittal dates, and depict the review and approval periods as defined in the Contract Documents for Department review.

Item 639.1022 01 – CPM (CRITICAL PATH METHOD) PROGRESS SCHEDULES – TYPE 2

The following activities shall be incorporated into the Progress Schedule:

Activity ID	Activity Description	Duration (Min)	Follows	Logic Tie	Responsibility
00001	Contract Letting Date	0 - Start Milestone	----	SS	NYSDOT
00005	Preconstruction Schedule Meeting	1 Working Day	00001	SS	NYSDOT
00010	Preconstruction Meeting	1 Working Day	00001	SS	NYSDOT
00011	DMWBE Goals Submitted		00001	SS	Contractor
00015	DMWBE Goals Approved	15 Working Days	000011	FS	NYSDOT
00020	Contract Award Process	45 Calendar Days	00001	SS	NYSDOT
00025	Contract Award Date	0 - Finish Milestone	00020	FF	NYSDOT
00030	Submit Proof of Insurance	1 Working Day	00001	SS	Contractor
00035	Notification to Proceed	1 Working Day	00025, 00030	FS	NYSDOT
00040	Submit Safety & Health Plan	1 Working Day	00001	SS	Contractor
00045	Approve Safety & Health Plan	20 Working Day	00040	FS	NYSDOT
00050	Contractor Starts Contract Work	0 - Start Milestone	00035, 00045	FS	Contractor
00055	Set Up Engineer's Field Office		00035	FS	Contractor
00060	Prepare & Submit Baseline Progress Schedule @ Award	See Note 1	00005	FS	Contractor
00065	Review Baseline Progress Schedule @ Award	See Note 2	00060	FS	NYSDOT
00070	Accept Baseline Progress Schedule @ Award	1 Working Day (see Note 3)	00065	FS	NYSDOT
00075	Mobilization	20 Working Days	00050	SS	Contractor
00100	Field Work Begins	0 duration	00050, 00055, 00060		Contractor
09000	Substantial Completion	0 duration	See definition	FS	Contractor
09010	Other Agency Inspection	20 Working Days	09000	FS	Others
09020	NYSDOT Inspection	20 Working Days	09000	FS	NYSDOT
09030	Punchlist work	20 Working Days	09020	FS	Contractor
09040	Demobilization	10 Working Days	09020	FS	Contractor
09100	Project Acceptance by the Engineer	0 duration	09040	FS	NYSDOT

Item 639.1022 01 – CPM (CRITICAL PATH METHOD) PROGRESS SCHEDULES – TYPE 2

Note 1 – Use Timeframe required in Table 2 column 1 of specification for Item 639.1022 xx.

Note 2 – Use Timeframe required in Table 2 column 2 of specification for Item 639.1022 xx.

Note 3 – Acceptance Date should not exceed Timeframe from Notice of Award required in Table 2 column 3 of specification for Item 639.1022 xx.

The Logic Tie shown shall be used as a relationship to the predecessor activities contained in the column named Follows.

iii) **Work Breakdown Structure (WBS)** - A multi level hierarchal WBS shall be incorporated. The levels (nodes) shall include, but not be limited to:

- Level 1 - is the project level;
- Level 2 - shall have three nodes; Preconstruction Activities, Construction Activities, and Post Construction Activities;
- Level 3 - Preconstruction activities shall have two sub nodes; Submittals/Shop Drawing Activities, and Procurement /Fabrication Activities);
 - Construction activities shall be broken into nodes for various geographic “Areas” of work within the project limits;
- Level 4 - the Areas of work shall have sub nodes for the various Stages of work;
- Level 5 - the Stages of work shall have sub nodes for the various highway features: bridges, highway segments, interchanges, intersections/roundabouts, etc;
- Level 6 - the highway features should be broken into their components (a bridge into components such as Piles, Substructure, Superstructure), and a highway segment into components such as pavement, drainage, earthwork, lighting, traffic signals, etc.

An example Work Breakdown Structure is shown below:

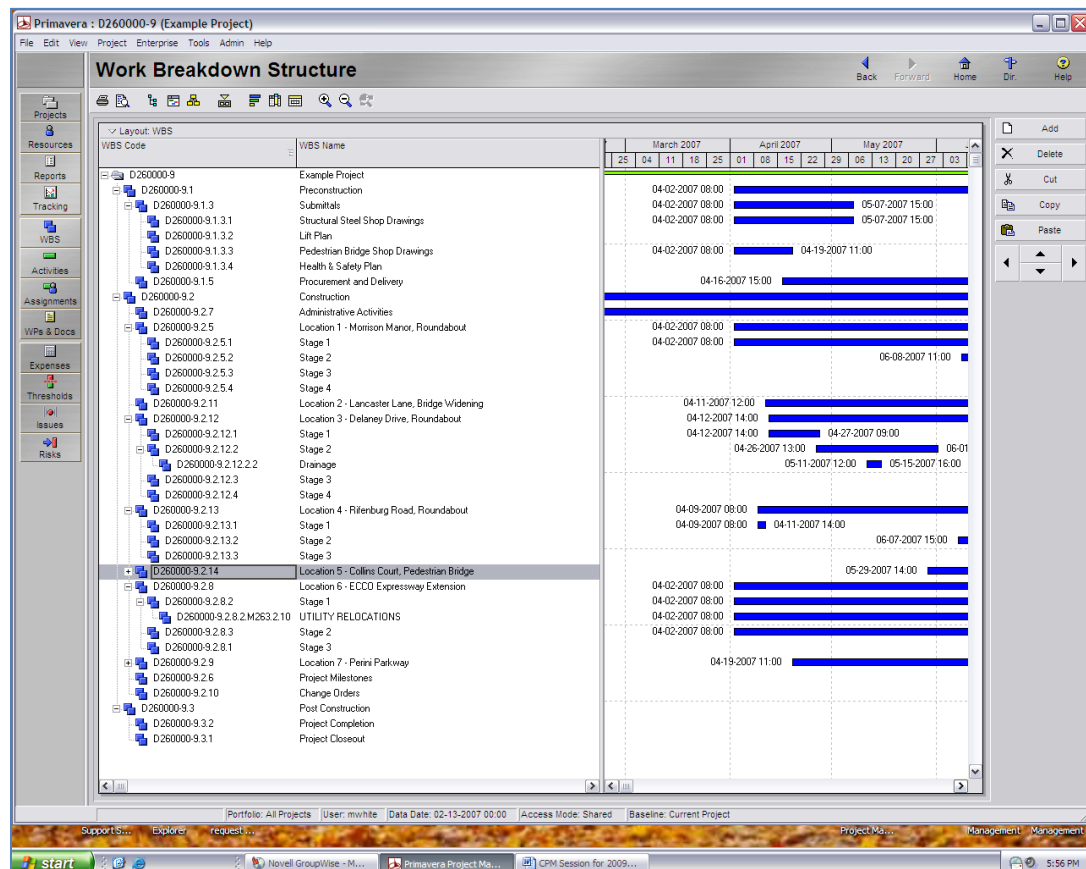

Item 639.1022 01 – CPM (CRITICAL PATH METHOD) PROGRESS SCHEDULES – TYPE 2

- iv) **Activity ID** - Include a unique identification number for each activity. Activity ID numbers shall not be changed, or reassigned.
- v) **Activity Name** - Clearly and uniquely define each activity name with a description of the work that is readily identifiable to inspection staff and the progress of each activity can be measured. Each Activity shall have a narrative description consisting at a minimum of a verb or work function (i.e. form, pour, excavate, etc), an object (i.e. slab, footing, wall, etc), and a location (i.e. STA, bridge or retaining wall number, street, etc). The work related to each Activity shall be limited to one Area of the contract, one Stage of the contract, one WZTC Phase of the contract, and one Responsible Party of the contract.
- vi) **Milestone Activities** - Include activities for all contract milestones that define significant contractual events such as Contract Award, Notice to Proceed, Contractor Start Work, Substantial Completion, Physical Completion, Contract Completion, and coordination points with outside entities such as utilities, State agencies, Authorities, municipalities, Time-Related Contract Provisions, etc.
- All milestone activities in the schedule shall be assigned the standard Global calendar named ‘NYSDOT Milestone/Curing 365 Day / 8 hour’, this calendar should also be assigned to any activities for concrete curing.
- The Contract Award milestone shall have a primary constraint of “Finish On” and the date of Contract signature by the State Comptroller,
 - The Contract Completion milestone shall have a primary constraint of “Finish on or before” and the contract Completion Date.
 - The Contractor Start Work” Start milestone activity, that will eventually reflect the actual date the Contractor started work authorized under the contract.
- vii) **Activity Durations** – Define the Original Duration of each activity in units of whole work days, except for activities of less than one day duration which should be shown in units of tenths of a day. Except submittal/procurement activities, durations shall not exceed 15 work days unless approved by the Engineer. Durations for Department submittal reviews shall meet the requirements set forth in the contract documents. If requested by the Engineer, the Contractor shall justify the reasonableness of planned activity time durations.
- viii) **Activity Relationships** - Clearly assign predecessors and successors relationships to each activity, and assign appropriate logic ties between activities (Finish to Start, Start to Start, Finish to Finish, etc). Do not have any open ended activities, with the exception of the first activity and last activity in the schedule. An activity may only appear once as a predecessor or successor to another specific activity, but may be assigned as a predecessor or successor to many different activities. Do not include inappropriate logic ties with Milestone activities (i.e. – a finish milestone activity, and a predecessor assigned with a Finish to Start logic tie; or a start milestone, and a successor assigned with a Finish to Start logic tie). **Lag time may not exceed 10 days. The Contractor shall not use negative Lag times.**
- ix) The Contractor shall assign the “Contract Award Date” activity as a predecessor to all Review and Approval type activities to be performed by Department staff.
- x) **Activity Constraint Dates** – The Contractor shall not have any constrained activities, with the exception of contractual dates, unless the Engineer accepts such constraints in writing. Milestone activities shall be included for the Contract Award which shall have a primary constraint of “Finish On” and the date of contract signature by the State Comptroller, and for the Contract Completion which shall have a primary constraint of “Finish on or before” and the contract completion date indicated in the contract documents. Only contractual/owner-designated constraints are allowed unless specifically authorized by this specification or the Engineer.
- xi) **Activity Dates** – With the exception of contract Milestone dates, “Actual Start” and “Actual Finish” dates and “Planned Start” and “Planned Finish” dates, activity dates shall be calculated by the project scheduler tool within the Primavera software. No Actual Start or Actual Finish dates

Item 639.1022 01 – CPM (CRITICAL PATH METHOD) PROGRESS SCHEDULES – TYPE 2

shall be entered in the Baseline Progress Schedule @ Award, with the exception of activities that were completed prior to the Contract Award.

- xii) **Calendars** - Use clearly defined calendars that account for expected seasonal weather conditions (including winter shutdown periods) and environmental permit requirements, for the planning and scheduling of activities. Do not incorporate an activity with a description of “Winter Shutdown” that requires constraints. Provide the working days per week, holidays, the number of shifts per day, and the number of hours per shift by using the Calendar modifier in the P6 software. Incorporate any seasonal restrictions to the work within calendars assigned to activities.
- Calendars related to specific resources (i.e., a specific person or piece of equipment) shall be established as Resource Calendars, with the Calendar name clearly identifying the resource.
 - All other calendars developed by a Contractor shall be established as Project Calendars, with the calendar name including the contract D# and describing the function (i.e., D260000 - Asphalt Calendar, D260000 - Concrete Calendar, D260000 - Landscape Calendar, D260000 - Painting Calendar, D260000 – Contractor’s 5 Day/8 Hour Workweek). All work activities of the Contractor shall be assigned to Project Calendars.
 - Any Global calendars used in the progress schedule shall be those established by the Department. There are only two Global Calendars developed and maintained by the Department for use by Contractor’s, they are the following:
 - NYSDOT Milestone/Curing 365 Day / 8 hour
 - State Business Days, 5 Day Work Week w/State Holidays, Field
- Changes desired for these calendars shall be forwarded to CPMSchedulingSection@dot.state.ny.us, and if appropriate these changes will be performed by the Office of Construction system admin staff. This will be accomplished by making a copy of the existing Global calendar, then the new calendar will be renamed and modified as necessary.
- Activities for shop drawing reviews and other approvals by Department personnel shall be assigned the Department’s standard Global – “State Business Day, 5 Day Work Week w/State Holidays, Field” Calendar that reflects all holidays observed by the State.
- xiii) Clearly define significant interaction points between the Contractor, the Department, and other entities including but not limited to: Federal, State and local agencies/authorities; and utilities. All activities of the Department, utility companies, adjacent contracts, and other entities that affect progress and influence any contract required dates including durations shall be shown in the schedule. This includes dates related to all Permits or Agreements. The schedule shall give special consideration to sensitive areas such as road closures and parklands and shall indicate any time frames when work is restricted in these sensitive areas as outlined in the permits issued by the regulatory agencies, and provided in the contract documents.
- xiv) **Activity Resources** – The Contractor will generally not be required to develop Labor resources, Equipment resources or Contract Pay Item resources in the Resource Dictionary, or assign them to schedule activities. The Contractor may be required by the Engineer to assign Labor and Equipment resources if submitting a Progress Schedule when contract milestone activities are projected to have Early Completion dates, as described in paragraph I of this specification. The Contractor will not be required to assign costs to resource assignments in the schedule. The Department will assume when reviewing the schedule that the Contractor’s resources are unlimited; unless the Contractor either assigns equipment, labor and contract pay item resources to each activity in the schedule (and performs resource leveling), or indicates in the schedule narrative what resource limitations are present. If labor, equipment and contract pay item resources are not assigned to activities in the schedule, it shall be the Contractor’s responsibility to assure the activity logic in the schedule properly reflects their resource limitations. If labor

Item 639.1022 01 – CPM (CRITICAL PATH METHOD) PROGRESS SCHEDULES – TYPE 2

and equipment resources are not assigned to activities in the schedule, and the Contractor anticipates multiple crews for the same schedule activity, these resources shall be documented in the schedule narrative. As an activity can have only one responsible party, no activity shall involve multiple crews comprised of the Contractor and a subcontractor, or multiple subcontractors.

- xv) **Activity Codes** – The Contractor shall include a well-defined activity coding structure that allows project activities to be sorted and filtered. Activity Codes shall include, but not be limited to: Responsible Party; Stage; Area of Work; Type of Work; Subcontractor; and additionally as required by the Engineer to meet the needs of the specific contract work to facilitate the use and analysis of the schedule.
- No Global Activity Codes shall be incorporated in any progress schedule submission to the Engineer except those established by the Department.
 - The Global activity codes established by the Department shall be used to the maximum extent practicable. The Contractor shall assign the appropriate activity code values to each activity in the progress schedule for the following Global Activity Codes that are in the Department’s enterprise database:
 - 1) RESPONSIBLE PARTY (DOT GLOBAL)
 - 2) STAGE (DOT GLOBAL)
 - 3) AREA (DOT GLOBAL)
 - 4) TYPE OF WORK (DOT GLOBAL)
 - 5) PAY ITEM (DOT GLOBAL)
 - 6) CHANGED (ADDED/DELETED) WORK (DOT GLOBAL)
 - 7) TIME Related Clauses (DOT GLOBAL)
 - 8) DELAY (DOT GLOBAL)
 - Additional Activity Codes developed for specific projects shall be established as Project Activity Codes.
- xvi) **Activity Code Values** – Each Activity Code shall be broken down into various Activity Code Values that are then assigned to activities. For example, the Activity Code “Stage” shall include a hierarchal arrangement of Activity Code Values as shown below in Figure 2:

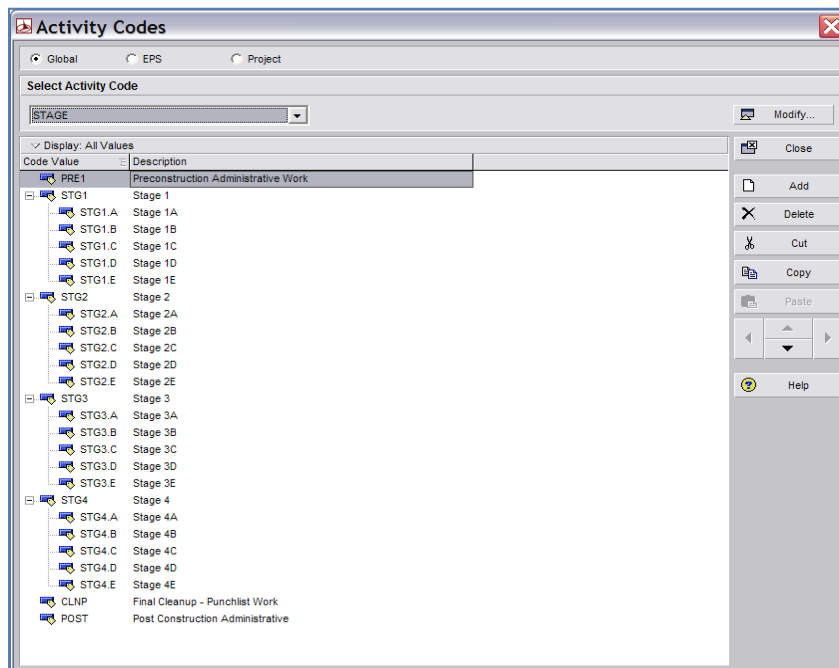

Figure 2

Item 639.1022 01 – CPM (CRITICAL PATH METHOD) PROGRESS SCHEDULES – TYPE 2

- xvii) **Activity Code Assignments** - For each activity, within the activity details the Contractor shall assign Activity Code values to identify the “Responsible Party” (i.e. – Contractor, NYSDOT, Utility Co, Municipality) for the work to be performed (one and only one responsible party shall be assigned to each activity), the “Stage” of the contract for the work that will be performed, the “Area” where the work is to be performed, the “WZTC Phase”, and the Type of Work (i.e. - Procurement, Paving, Embankment, Excavation, Electrical, Signing, etc). For activities included in work governed by time-related contract provisions, the appropriate “Time Related” activity code shall be utilized. For activities included in work added and/or changed within an Order-On-Contract, the appropriate “Added/Changed Work” code shall be utilized. For all work activities performed by the Contractor or subcontractors/fabricators/suppliers, “Contractor” shall be designated as the Responsible Party. If the Contractor wants a separate activity code to enable sorting the activities of subcontractors, fabricators, or suppliers a separate “Subcontractor” code shall be utilized.
- xviii) **Interim Milestone Dates with Liquidated Damages and Special Time-Related Contract Provisions** (i.e. – A+B Bidding, Incentive/Disincentive provisions, Lane Rental) – Each time-related contract provision in the contract shall be represented in the progress schedule by having a start and finish milestone, with appropriate predecessors and successors assigned to all schedule activities considered part of that time-related contract provision work including the start and finish milestone activities. In addition, the Start milestone for the time-related contract work shall have predecessors and/or date constraints assigned that include those defined in the contract documents, and the Finish milestone for the time-related contract work shall have successors and/or date constraints assigned that include those defined in the contract documents. All schedule activities associated with each specific time-related contract provision shall be assigned to a separate node within the project WBS and the WBS node description shall be labeled accordingly, in addition these activities shall be assigned the appropriate Time-Related Clauses (DOT GLOBAL) activity code value. A Level Of Effort activity shall be used for each time related contract provision (i.e - “Incentive 1 Duration” or “B Clock 1 Duration”), this activity shall have the Start Milestone as a predecessor with a SS relationship and the Finish Milestone as a successor with a FF relationship and the duration of this activity shall be calculated when the project is scheduled.
- xix) **Narrative** - Include a narrative in Microsoft Word and/or Adobe Acrobat format that describes:
- The Contractor’s general approach to construct the Work outlined in the baseline schedule. Address the reasons for the sequencing of work and describe any resource limitations, potential conflicts, and other salient items that may affect the schedule and how they may be resolved.
 - If not provided in the contract plans, or if modified by the Contractor, provide copies of the appropriate contract plan sheets marked up as Key Plans, to correlate values on the contract plans (for Area of Work, Stage of Work, and WZTC Phase) to the Contractor’s planned breakdown of the project (ie- Activity Codes, Activity Descriptions) for scheduling purposes.
 - The justification(s) for each activity with a duration exceeding 15 working days.
 - The reason for any lags assigned to any activities.
 - The justification(s) for Contractor imposed activity constraints proposed in the schedule.
 - A list of calendars which have been used in the schedule, along with the general reason for their use.
 - The project critical path and challenges that may arise associated with the critical path.
 - Anticipated coordination issues related to work activities by other entities, that require additional information from or action by the Engineer.

Item 639.1022 01 – CPM (CRITICAL PATH METHOD) PROGRESS SCHEDULES – TYPE 2

- Appendix 1 to the narrative shall be the “Schedule Log” report created when the project was scheduled.
 - Appendix 2 to the narrative shall be an electronic schedule plot (Adobe Acrobat format) using the Global Layout named “Baseline Schedule submission”, with activities sorted by Start Date in ascending order, Grouping of activities by WBS, and only the “Longest Path” filter applied. This plot shall provide a clear critical path from the Data Date to the last activity in the schedule.
- xx) **List of Submittals** – The Contractor shall submit with the Progress Schedule a list of all Submittals (i.e. - Shop Drawings, required permits, Erection/Demolition plans, Health and Safety Plan, etc.) generated from the Baseline Progress Schedule for review and approval by the Engineer. The Contractor shall use a Filter to limit the schedule activities shown in the report to only the prepare/submit, and review/approve activities related to submittals. For construction contracts that utilize Primavera Contract Manager, Shop Drawing submittal activities in the Progress Schedule shall be at the Submittal Package level. The report shall be in Adobe PDF format and transmitted to the Engineer by email.
- e) Schedule Submission
- i) Within the timeframe indicated in Table 2 column 1, submit one electronic copy of the Baseline Progress Schedule @ Award in a Critical Path Method (CPM) format for the Engineer’s review and acceptance.

TABLE 2 (in State Business Days)		
Timeframe from receipt of Notice of Award to Submission of complete Baseline Schedule. (Column 1)	Timeframe for Engineer’s Review (Column 2)	Timeframe from Notice of Award to acceptance by the Engineer not to exceed (Column 3)
10	10	40

- ii) The Engineer will review the schedule and return it, accept it with comments, or reject it within the timeframes indicated in Table 2 column 2, following the date of receipt of the Contractor’s submission.
- iii) If the schedule is returned with comments, the Contractor shall address all comments and revise the schedule as necessary. The Contractor shall complete the Final Baseline Progress Schedule @ Award and obtain the acceptance of the Engineer within the timeframe required in Table 2 column 3.
- iv) If the schedule is accepted by the Engineer without any comments, the Contractor shall copy the schedule and rename it for submission as the Final Baseline Progress Schedule @ Award.
- v) **In no way does the Baseline Progress Schedule modify the contract documents.**
- vi) The Contractor shall assign appropriate Activity Codes and provide custom Layouts, Filters, and/or report formats necessary to allow the Engineer to generate a report from the each Progress Schedule submission of all submittals required under the contract (i.e., shop drawings, required permits, erection/demolition plans, etc). The list shall show scheduled submission date, review date, and acceptance date for each submittal and identify the earliest activity affected by each of these submittals. This list shall be generated from each Progress Schedule submission until all such activities are completed.

3. Final Baseline Progress Schedule @ Award

- a) If the Baseline Progress Schedule @ Award is returned to the Contractor with comments, the Contractor shall make a copy of the schedule and rename it as the Final Baseline Progress Schedule @ Award with comments addressed and revisions made as necessary. The Contractor shall complete the Final Baseline Progress Schedule @ Award and obtain acceptance of the Engineer within the timeframe required in column 3 of Table 2, or within one week of the Contractor's receipt of the final comments by the Engineer, whichever is sooner.
- b) The Engineer shall review the schedule and return it, accepted or with comments, within 5 State Business days following the date of receipt of the Contractor's submission.
- c) The Final Baseline Progress Schedule @ Award must be "accepted" or "accepted as noted" by the Engineer prior to the Department evaluating any Contractor disputes associated with time impacts. This does not preclude the Contractor from submitting a dispute while the schedule is being reviewed for acceptance.

4. Monthly Progress Schedule Submissions.

- a) First Monthly Progress Schedule Submission – Within three State Business Days following acceptance of the Final Baseline Progress Schedule @ Award or the closing date for the first months contract payment period whichever is later, the Contractor shall perform a Progress Schedule Update to reflect the status of all activities where work was performed in the time period between the start of work and acceptance of the Final Baseline Progress Schedule @ Award. This shall include actual dates entered in the Actual Start and Actual Finish columns, and percentage of work complete for uncompleted activities, in addition the Contractor shall incorporate any Progress Schedule Revisions that reflect any changes in how future work activities are to be completed.
- b) Subsequent Monthly Progress Schedule Submissions - On a monthly basis, the Contractor shall submit a copy of the current Progress Schedule that includes all Progress Schedule Revisions and Progress Schedule Updates to reflect the actual and planned prosecution and progress of the contract work. Progress Schedule Updates shall reflect the status of activities that have commenced or have been completed, including the following items: (a) actual dates in activity Actual Start and Actual Finish columns as appropriate; (b) actual Remaining Duration for activities commenced and not complete; and (c) actual activity Suspend or Resume dates for activities commenced and not complete. Progress Schedule Revisions reflect modifications made to activities in the current project baseline schedule in any of the following items: (a) activity Original Duration; (b) changes in logic connections between activities; (c) changes in Constraints; (d) changes to Activity Descriptions; (e) activity additions or deletions; (f) changes in Activity Code assignments; (g) changes in activity Resource assignments; and (h) changes in Calendar assignments. All "Out of Sequence" activities noted in the scheduling log shall be corrected to reflect the current construction operations.

When preparing a formal submission of the progress schedule, the Contractor shall make a copy of the current Progress Schedule and name it according to the file naming convention provided by the Department in Table 1.

- c) Additional Schedule Requirements - In addition to the schedule requirements detailed for the submission of the Baseline Progress Schedule @ Award, the following shall be provided by the Contractor:
 - ii) **Data Date** - the "Data Date" shall be the date the Project Scheduler last edits the schedule prior to submission to the Engineer (generally the last working day of the contract payment period). The Project Scheduler can modify the project's Data Date through the Schedule tool.
 - iii) Activity Status -
 - a. Durations – the Original Duration shall not be changed without prior written justification by the Contractor, and written approval by the EIC. The Contractor shall edit the Remaining Duration to reflect progress made on work activities, and shall not use Duration % . If a proposed change to Original Duration is due to additional or changed work to the contract the Contractor shall instead add an activity to reflect this additional work, and assign the appropriate Activity Code.

Item 639.1022 01 – CPM (CRITICAL PATH METHOD) PROGRESS SCHEDULES – TYPE 2

- b. Started and Finished dates – for each activity where work was started during the month, the Contractor shall enter the date the work Started. For each activity where work was completed during the month, the Contractor shall enter the date the work Finished.
- c. Suspended work – The first time that work has been suspended on a schedule activity, the Contractor shall enter the Suspend and Resume fields within the Project Details under the Status tab. For any subsequent suspensions of work to that activity the Contractor shall break that activity into two or more activities to accurately reflect the suspension and resumption of work dates in the field, and to more accurately reflect the relationship to other work activities.
- iv) Activity Resources – For each activity that resource limitations are affecting the prosecution of work, as determined by the Engineer, labor and equipment resources shall be entered in the schedule. Unit costs or pricing is not required. Labor Resources shall identify resources that encompass direct labor at the Crew level (i.e. – Grade Crew 1, Paving Crew 1, Pipe Crew 1, Bridge Footing Crew 1, Bridge Deck Crew 1, etc), the makeup of the Crew shall include the various Labor classes and equipment that comprise the Crew along with the quantity of each labor class and type of equipment. The Contractor shall provide the makeup of each Crew in the Schedule Narrative, and assign those Crews to the appropriate activities in the Progress Schedule. Equipment resources shall be shown for major or specialty equipment such as tower cranes, pile drivers, barges, asphalt pavers, concrete pavers, dozers, front end loaders, backhoes, rollers, excavators, graders, long line striping trucks or other equipment that cannot be rented easily.
- v) Calendars – To change a project calendar for activities scheduled in the future, the Contractor shall copy the calendar and use a revised name that includes a reference to which Monthly Update the change was incorporated (i.e. - D260000 - Concrete Calendar should be revised to D260000 – 2 - Concrete Calendar to reflect the 2nd Monthly Update when the change was made to the calendar). The reason for the change in the calendar shall be documented in the Narrative.
- vi) Notebook - For any activities on the critical path that are delayed, the Contractor shall enter the dates the activity was delayed and the reason for such delay in the Notebook tab of that activity.
- d) **Monthly Progress Schedule Narrative - For each Monthly Progress Schedule submission, the Contractor shall submit a narrative in Microsoft Word, or Adobe Acrobat format that includes, but is not limited to: (The narrative may be an annotated copy of the Claim Digger Report that includes the information below.)**
 - i) The contract D number, project name, project location, and name of Prime Contractor.
 - ii) Actual contract Award Date, current contract Completion Date, and scheduled completion of all project work.
 - iii) Any contact Interim Milestone dates (I/D, B-Clock, LD, etc), and scheduled Start and Finish dates for those Milestone activities.
 - iv) List all activities on the Critical Path (include Activity ID's and Activity Descriptions) where work is currently being delayed, and for each such activity provide detailed information including:
 - the events that caused the delay.
 - the party(s) responsible for the delay event(s).
 - the number of days the activity has been delayed (negative float).
 - the activities in the construction schedule affected by the events.
 - the reasonable steps needed to minimize the impact of the delay, and which party needs to take the action(s).

Item 639.1022 01 – CPM (CRITICAL PATH METHOD) PROGRESS SCHEDULES – TYPE 2

- v) List any other problems experienced during this Progress Schedule submission period, the party responsible for the problems, and the Contractor's intentions to resolve the problems.
- vi) List all activities for procurement of long lead time materials that are behind schedule and the reason(s) why.
- vii) For major work items describe the differences between the actual work performed and the work planned for the period as represented in the preceding Progress Schedule submission, including explanations for the deviations.
- viii) For all suspended work activities that could otherwise logically be progressed, identify the responsible party prohibiting the progression of the work, as well as the detailed reasons why.
- ix) Description of any changes to the critical path since the last Monthly Progress Schedule submission and the impacts of such changes.
- x) Change to State Owned Float and/or Contractor Owned Float based on changes to the critical path.
- xi) List of all added or deleted activities included in this Monthly Progress Schedule submission, and the reason(s) for and the impact(s) of such changes.
- xii) List all changes in activity Original Durations, the justification for such change(s), and the impact(s) of such changes.
- xiii) List all changes in relationships between activities included in this Progress Schedule submission, and the reason(s) for and the impact(s) of such changes.
- xiv) List any addition or deletion of activity or project constraints, and the reason(s) for and the impact(s) of such changes.
- xv) List all changes to the project calendars, and the reason(s) for and the impact(s) of such changes.
- xvi) The major work elements, as defined in the WBS, to be accomplished during the next monthly work period.
- xvii) Any potential problems that are anticipated for the next monthly work period and the proposed solutions to such problems. Identify potential problems or risks that either the Department or Contractor may be potentially responsible for. Explain what action the responsible party (i.e. - Department or Contractor) needs to take and the date by which time the action needs to be taken to avoid the problem.
- xviii) Any planned acceleration of activities that the Contractor anticipates to undertake within the next monthly work period that either the Department directed, or that the Contractor believes is necessary.
- xix) The following appendix in Adobe Acrobat PDF file format, formatted to fit ANSI Size D paper (610 mm x 914 mm) (24 inch x 36 inch) paper, shall be included with the narrative.
 - APPENDIX 1 – A listing of all work activities as of the data date, using the Classic Schedule Layout, sorted by Early Start Date, Total Float in increasing order, showing the Activity ID, Activity Description, Original Duration, Remaining Duration, Total Float, Early Start date, Early Finish date, Start date, Finish date, and Calendar ID. The grouping of activities shall be by Area, Stage, WZTC Phase, and Type of Work. The Gantt Chart shall clearly indicate the project critical (longest) path. Graphical representations shall be shown at a suitable scale to be legible and readable.The following appendices in Adobe Acrobat PDF file format, formatted to fit 216 mm x 279 mm size (8.5 inch x 11 inch) paper, shall be included with the narrative.
 - APPENDIX 2 – A complete Scheduling/Leveling Report (SCHEDLOG.TXT file generated by the Department's Primavera scheduling software application) which includes the Schedule Settings, Statistics, Errors, Warnings, Scheduling/Leveling Results, Exceptions, Activities with unsatisfied constraints, Activities with unsatisfied relationships, and Activities with external dates. The statistics shall include, # of

Item 639.1022 01 – CPM (CRITICAL PATH METHOD) PROGRESS SCHEDULES – TYPE 2

Activities, # of Activities Not Started, # of Activities In Progress, # of Activities Completed, # of Activity Relationships, and # of Activities with Constraints. Total number of activities on the critical path, percent complete, activities without predecessors, activities without successors, and activities out of sequence.

- APPENDIX 3 – Claim Digger Report (generated by the Primavera software application) providing a comparison between this Progress Schedule submission and the previous Progress Schedule submission.
- e) The Contractor shall include a Time Impact Analysis (TIA) with any request for an extension of contract time.

- f) Schedule Submission - The Contractor shall submit the Monthly Progress Schedule to the Engineer monthly using the closing date for the monthly contract payment. The schedule submission to the Engineer shall be made within three (3) State Business Days of the Data Date, whether or not the Engineer has accepted the previous Monthly Progress Schedule submission. Schedule submittals will only be considered complete when all documents and data have been provided.

Immediately prior to submitting the schedule the Project Scheduler shall “Schedule” the project, when scheduling the project the Scheduling Options shown in Figure 3 shall be used unless approval to vary from these settings is given by the Engineer, or if the schedule has an Early Completion Date(s) as outlined in paragraph I of this specification the option to Level Resources during Scheduling shall be checked. The Project Scheduler shall use the same Scheduling Options for all Progress Schedule submittals for the duration of the contract, unless directed otherwise by the Engineer.

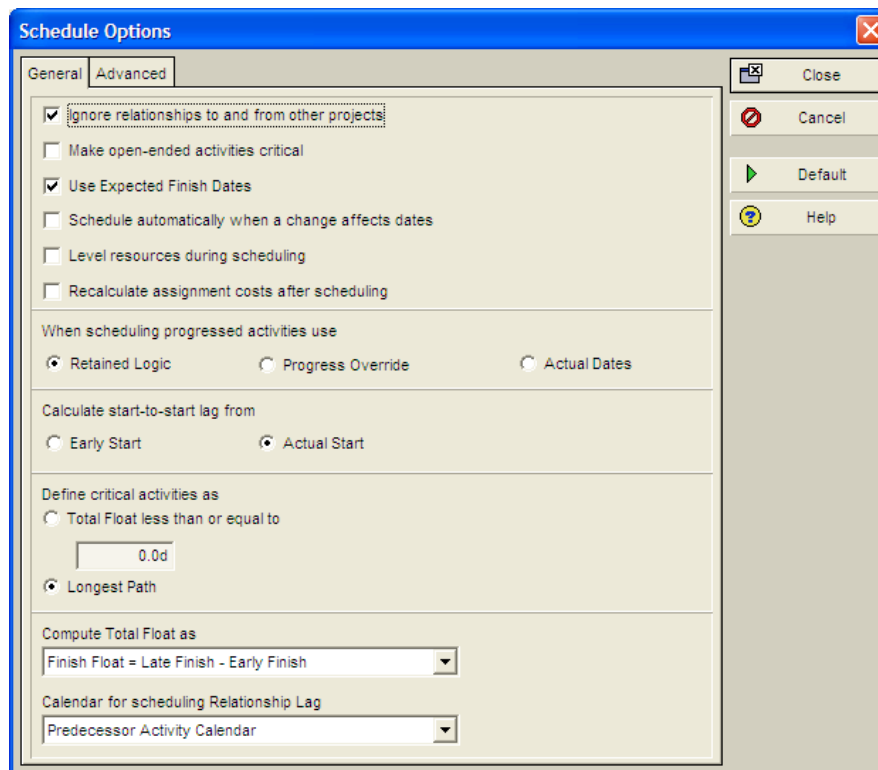

FIGURE 3

- g) Schedule Submission Method - The Contractor shall submit the schedule to the Engineer electronically for review and acceptance. The filename shall conform to the requirements of Table 1. The Project Scheduler can change the Project ID and Name through the WBS at the top node, as they do not have privileges to edit data through the Project Details tab. The Contractor’s submission shall be documented by an E-mail to the Engineer, with a copy to CPMSchedulingSection@dot.state.ny.us

Item 639.1022 01 – CPM (CRITICAL PATH METHOD) PROGRESS SCHEDULES – TYPE 2

and all appropriate project participants, that the project schedule on the network is ready for review.

The Contractor's E-mail to the Engineer shall also consist of the following:

- i) The subject of the E-mail shall include the Region #, contract D number, the Project Name, the Progress Schedule's ProjectID, and construction company name. (i.e. – Region 8, D260000, Rehabilitation of Main Street viaduct, D260000-1UD2, ABC Contractors)
- ii) The E-mail message shall include the name of the EIC, the current anticipated Finish date of the last activity in the project schedule, a statement as to how that date compares to the current Contract Completion Date, and the name of the Area Construction Supervisor.
- iii) Electronic files of all Narrative Reports and required attachments associated with the schedule shall be submitted by the Contractor in Adobe Acrobat format.

5. As-Built Progress Schedule. The Contractor shall submit the As-Built Progress Schedule with Actual Start and Actual Finish dates for all activities, within ten (10) State Business Days following final acceptance of work by the Regional Director.

6. Look-Ahead Schedule.

Except during winter shutdown periods the Contractor shall prepare a Look-ahead Schedule as either a plotted report from the current progress schedule, or as a narrative report, and provide it to the EIC on a weekly basis, or if approved by the Engineer on a mutually agreed upon interval. The Look-ahead schedule shall include work activities planned for the next one or two week period, as determined by the Engineer, and shall include, but is not limited to: anticipated lane closures, road closures and detours, environmental issues, and utility issues. The Engineer will provide the Project Scheduler with guidelines for determining the begin dates and end dates for the one or two week reporting periods, along with the how the plotted schedule report or narrative report shall be formatted.

The Department generally uses this Look-ahead schedule to facilitate communication with other Federal or State agencies, local municipalities, utility companies, railroads, emergency service providers, public news media and other affected parties.

E. Progress Schedule Review and Analysis:

1. Immediate Rejection of Progress Schedule Submissions.

The following deficiencies in a Contractor's progress schedule submission shall be grounds for the immediate rejection by the EIC, without further review, analysis and/or comments.

- a) Failure of the Project Scheduler to "schedule" the project, as of the data date.
- b) Failure to attach a copy of the complete Scheduling/Leveling Report (SCHEDLOG.TXT file generated by Primavera software application).
- c) Any activities without predecessors, or activities without successors, appearing in the Scheduling/Leveling Report with the exception of the first and last activity in the schedule.
- d) Any activity constraints appearing in the Scheduling/Leveling Report that have not been approved in writing by the EIC, or that are not specifically allowed by this specification.
- e) Any Activities with Actual Dates > Data Date appearing in the Scheduling/Leveling Report.
- f) Any Milestone Activities with invalid relationships appearing in the Scheduling/Leveling Report.
- g) Failure to have a clearly defined Critical Path from the Data date to the last activity in the schedule, using the Longest Path method. This would reflect logic errors in the project schedule.
- h) Failure to attach the schedule Narrative and required appendices.
- i) Failure to attach the Claim Digger Report (generated by the Department's Primavera scheduling software application) providing a comparison between this Progress Schedule submission and the previous Progress Schedule submission. (Not required for baseline submissions)

If any of these deficiencies are found, the Contractor's submission shall be considered deficient, and Engineer will notify the Contractor immediately by return E-mail of the rejection of the schedule submittal.

Item 639.1022 01 – CPM (CRITICAL PATH METHOD) PROGRESS SCHEDULES – TYPE 2

If the Contractor fails to submit a CPM Progress Schedule conforming to the provisions required under this specification, to the degree that such failure is deemed by the Regional Construction Engineer to adversely affect the management of the project and/or the administration of the construction contract, liquidated damages will be assessed as determined under Basis of Payment.

2. **Schedule Analysis Method.**

Events, actions, and progress that cause delays or gains to the Progress Schedule will be analyzed solely by the "Contemporaneous Period Analysis" method.

3. **Project Progress Meetings.**

One topic of the regular progress meetings held by the Engineer and attended by the Contractor shall be a review of the Weekly Status Report generated from the Progress Schedule. The Contractor shall be represented by the Field Superintendent and Project Scheduler. The Project Scheduler shall bring a copy of the printed plot of the current Weekly Status Report to the progress meeting, the report shall show the current anticipated schedule for all remaining work with the critical path activities highlighted.

- a) The review of the Status Report serves as the forum to discuss project progress and delays, suggested remedies, necessary Progress Schedule revisions, coordination requirements, change orders, potential Contractor time extension requests, and other relevant issues. If contract work is falling behind the Progress Schedule, the responsible party (i.e.- Contractor or Department) shall be ready to discuss what measures it will take in the next thirty (30) days to put the work back on schedule so as to meet the contract Completion Date specified in the contract.
- b) Items of discussion will include, but are not limited to: project progress; schedule progress; near term and long-term schedule issues, including RFIs, Shop Drawing submittals, permit work, utility relocations, mitigation work; project issues and risks; proposed solutions; and any relevant technical issues that are schedule related.
- c) At the meeting the Project Scheduler shall compile an action item list that describes who is responsible for existing or pending issues and the date by which the issue needs to be resolved to avoid delays. The Contractor shall forward a copy of the action item list to the Engineer within 2 business days following the meeting.

4. **Department Review and Acceptance of Progress Schedules.**

The Engineer will review the Monthly Progress Schedule submissions and will prepare a written response (Progress Schedule Review Report) to the Contractor's submission within five (5) State Business Days following receipt of the Contractor's complete schedule submission. The Engineer will either "accept" the schedule, "accept as noted", or "reject" the schedule for re-submittal by the Contractor.

If the Progress Schedule submission is not in compliance with contract requirements, the Engineer may reject the submittal and shall forward any comments and requests for schedule revisions to the Project Scheduler with a copy to the Contractor. The Project Scheduler shall address all comments in writing and/or make the requested revisions, and resubmit the revised schedule within three (3) State Business days of the Engineer's reply. If the Engineer determines the revised submission still does not meet the contract requirements, any further revisions required thereafter shall also be submitted for acceptance within (3) business days of the request for revisions by the Engineer.

For schedules that are "accepted as noted" the Engineer shall forward any comments, or requests for revisions, to the Contractor. The Project Scheduler shall address all comments in writing and/or make the requested revisions as part of the next scheduled Progress Schedule submission.

The Project Scheduler shall make adjustments to the Progress Schedule in accordance with the Engineer's comments and resubmit copies for review consistent with the requirements of this section.

Item 639.1022 01 – CPM (CRITICAL PATH METHOD) PROGRESS SCHEDULES – TYPE 2

The Engineer, by accepting the progress Schedule, does not agree that the Progress Schedule is reasonable or that by following the Progress Schedule the Contractor can complete the work in a timely manner. If, after a Progress Schedule has been accepted by the Engineer, either the Contractor or the Engineer discover that any aspect of the Schedule is on error, or something significant has been omitted, the Contractor shall correct the Progress Schedule in the next Progress Schedule submission and describe this revision in the Narrative report.

Acceptance of progress schedules by the Engineer shall not be construed to imply approval of any particular construction methods or sequence of construction or to relieve the Contractor from its responsibility to provide sufficient materials, equipment and labor to guarantee the completion of the contract in accordance with the contract documents.

Acceptance of the progress schedule by the Engineer does not attest to the validity of assumptions, activities, relationships, sequences, resource allocations, or any other aspect of the progress schedule. Within the contractual constraints, the Contractor is solely responsible for the planning and execution of the work.

Acceptance of the progress schedule by the Engineer shall not be construed to modify or amend the contract agreement or the date of completion therein. Completion dates can only be modified or amended by standard contractual means, through an official HC-250b Request For Extension of Completion Date.

If any resources are included in the Progress Schedule, it is not intended that the Engineer, by accepting the schedule should use the Contractor's resource data for anything other than determining the reasonableness of achieving the Contractor's production rates. Resources included with the accepted CPM schedule shall not be misconstrued as a cost benchmark for the performance of planned or actual work.

Once the progress schedule has been accepted, the Contractor shall not deviate from it without first notifying the Engineer in writing.

Upon receipt from the Contractor of the corrected schedule, a new review period by the Engineer of five (5) State Business days will begin.

F. Changes to Progress Schedule due to Added/Deleted/Changed Work:

- 1. Changes to the contract.** In the event a notice of a change to the contract is received, the appropriate changes to the progress schedule shall be made, as necessary, to incorporate the anticipated added/deleted/changed work and the Contractor shall notify the Engineer in writing within 10 (ten) calendar days if there is any effect of such change to the schedule. *Change to the contract includes, but is not limited to, extra work, Agreed Prices, Orders on Contracts, Suspensions of Work Directed by the Engineer, Changed Condition, and Value Engineering Change Proposals. Added, deleted and/or extra work associated with Orders On Contract shall be reflected in the next Monthly Progress Schedule Submission in anticipation of and prior to the date in which the work physically takes place without regard to the dates when the actual Order On Contract was approved.* The effect of the change to the contract on the projects Critical Path shall be stated. Extra work or additional work that does not affect the controlling operation on the critical path will not be considered as the basis for a time extension. All schedule activities effected by added, deleted or changed work that is included in a signed Order-On-Contract, Field Change Order, or Authorization of Extra Work (with the exception of minor quantity changes that do not impact contract milestones), or work activities performed by the Contractor at risk in anticipation of such Department approval,

Item 639.1022 01 – CPM (CRITICAL PATH METHOD) PROGRESS SCHEDULES – TYPE 2

shall be assigned the appropriate Activity Code (Added/Changed Work) and Code Value (sequentially numbered) to denote which “Changed Contract Work” order number correlates to those activities of work.

2. Time Impact Analysis.

A Time Impact Analysis (TIA) shall be submitted to the Engineer for each request by the Contractor for an adjustment of contract time, or when the Contractor or Engineer consider that an approved or anticipated change to the contract may impact the critical path and contract progress by more than a calendar month. The TIA shall be based on a revised Progress Schedule and shall be submitted as an electronic file (using Microsoft Word for the narrative) containing:

- a) The TIA shall illustrate the impacts of each change or delay on the current scheduled completion date or internal milestone, as appropriate.
- b) The analysis shall use the accepted Monthly Progress Schedule that has a data date closest to and prior to the event as the “Current Baseline”, this shall then be compared against the “What-if Project Plan Baseline” for the purpose of the TIA.
- c) If the Engineer determines that the accepted schedule used does not appropriately represent the conditions prior to the event, the accepted schedule shall be updated to the day before the event being analyzed.
- d) The TIA shall include an impacted schedule (“What-if Project Plan Baseline”) developed from incorporating the actual or anticipated event into the accepted schedule by adding or deleting activities, or by changing durations or logic of existing activities.
- e) If the impact schedule shows that incorporating the event negatively modifies the critical path and scheduled completion date of the accepted schedule, and the Engineer accepts the impacted schedule, the difference between scheduled completion dates of the two schedules shall be equal to the proposed adjustment of contract time.
- f) The Engineer may construct and utilize an appropriate project schedule or use another recognized method to determine adjustments in contract time until the Contractor provides the TIA.
- g) The Contractor shall submit a TIA within fifteen (15) State Business Days of receiving a written request for a TIA from the Engineer.
- h) The Contractor shall allow the Engineer ten (10) State Business Days after receipt to accept or reject the submitted TIA. All accepted TIA schedule changes shall be included in the next Monthly Progress Schedule submission.
- i) If a TIA submitted by the Contractor is rejected by the Engineer, the Contractor shall meet with the Engineer to discuss and resolve issues related to the TIA. If agreement is not reached, the Contractor will give notice in conformance with §104-06 Notice & Recordkeeping, and submit in accordance within the provisions in §105-14.E “Required Content of *Dispute Submissions*”.
- j) The Contractor shall only show actual as-built work, not unapproved changes related to the TIA, in subsequent Monthly Progress Schedules submissions. If agreement is reached at a later date, approved TIA schedule changes shall be included in the next Monthly Progress Schedule submission.
- k) Request for a contract time extension will not be processed until the receipt and approval of a Time Impact Analysis.

G. Failure to Submit Progress Schedules and/or Recovery Schedules:

- 1) No progress payment for this item of work shall be made until the progress schedule is “accepted” or “accepted as noted” by the Engineer.
- 2) If the Contractor’s Progress Schedule submission is rejected due to any deficiency noted in paragraph E.1(a) through (i), it shall be considered an incomplete submission and therefore substantially deficient.

Item 639.1022 01 – CPM (CRITICAL PATH METHOD) PROGRESS SCHEDULES – TYPE 2

- 3) If the Contractor's revised Progress Schedule submission does not address the written comments provided by the Engineer, and does not include a written explanation with a reasonable rationale for not addressing those comments, the submission shall be considered deficient.

H. Recovery Schedule

- 1) If the latest completion time for any work on the current Progress Schedule results in an activity being delayed ten percent or more of the time beyond the required Contract duration or any specified Milestone duration, as adjusted if appropriate, the Engineer may require the Contractor to submit a Recovery Schedule and written description of the plan to recover all lost time and maintain the required Completion Date or specified Interim Milestone Date(s).
- 2) With the Recovery Schedule the Contractor shall submit a narrative that identifies where additional labor and/or equipment resources will be allocated. Alternately, the Contractor may elect to provide the makeup of their Crew resources in the narrative, and assign those Crew resources to the appropriate activities in the Progress Schedule. The makeup of the Crew shall include the various Labor classes and equipment that comprise the Crew along with the quantity of each labor class and type of equipment. Equipment resources shall be shown for major or specialty equipment such as tower cranes, piledrivers, barges, asphalt pavers, concrete pavers, dozers, front end loaders, backhoes, rollers, excavators, graders, long line striping truck or other equipment that cannot be rented easily. Either of these alternatives may be supplemented with a request for a Contract Time Extension. The Contractor shall provide a reasonable plan for accomplishing the work of the contract within the current completion date, or to the requested contract extension date. The Engineer will use the Recovery Schedule to evaluate time extensions, with or without charges.

I. Additional requirements for progress schedules with projected Early Completion date(s):

- 1) The Contractor may show a projected early completion date on any progress schedule submission provided that all of the requirements of the contract are met. The Contractor may increase early completion time by incorporating a longer work week (6 Day/8 Hr Workweek instead of 5 Day/8 Hr Workweek), adding additional shifts, increasing the number of crews, reallocating resources to be more efficient, or adopting aggressive scheduling and construction management processes.
- 2) If the Contractor submits a progress schedule that indicates an anticipated early completion date(s) that is/are less than 90% of the specified contract milestone duration, the Progress Schedule submission shall be supplemented with Labor and Equipment resources assigned to every task activity in the schedule. The Contractor shall use resource leveling when scheduling the project and include time-scaled resource histograms with the Progress Schedule submission. The resource allocations must be shown to a level of detail that facilitates report generation based on labor crafts and equipment classes for the Contractor and subcontractors work. The Contractor shall, as a minimum, use average composite crew resources to display the labor loading of on-site construction activities and these crew resources in the resource dictionary shall identify the individual labor crafts comprised within the crew under the Notes tab of the crew resource. The Contractor shall optimize and level labor to reflect a reasonable plan for accomplishing the work of the contract and to assure that resources are not duplicated in concurrent activities.

J. Float

During the course of contract execution, Total Float generated due to the efficiencies of either party (State or Contractor) will generally be considered Project Float that is not for the sole use of the party generating the float; rather it is a shared commodity to be reasonably used by either party. Any party assigned activity responsibility within the schedule has the full use of the Project Float until it is depleted.

However, if the Contractor submits a request for an Early Completion that includes a revised Progress Schedule supplemented with resource allocations for each task activity and time-scaled

Item 639.1022 01 – CPM (CRITICAL PATH METHOD) PROGRESS SCHEDULES – TYPE 2

resource histograms that is accepted by the Department, then Total Float actually resulting from additional Contractor resources, additional work shifts, longer work weeks or adoption of more aggressive scheduling and construction management practices of the Contractor's work activities may be considered Contractor Owned Float for the exclusive use of the Contractor. Refer to paragraph I for resource loading requirements for Early Completion Dates.

The Department may accrue State Owned Float by generating Total Float through different means. This includes: change(s) to the contract that relaxes restrictions on the Contractor, removes contract work or reduces quantities of items of work; early completion of Utility company activities; and early completion of Shop Drawing or submittal reviews. State Owned Float is considered a resource for the exclusive use by the State. The Engineer documents State Owned Float by directing the Contractor to update the State Owned Float activity on the next Monthly Progress Schedule submission. The Engineer may use State owned Float to mitigate past, present or future State delays by offsetting potential time extensions for contract change orders.

For either the State or Contractor to reserve Total Float as State Owned Float or Contractor Owned Float the party must document within the schedule submission narrative in advance of generating the Total Float the additional resources or measures that will taken to shorten the critical path, and then document within the schedule submission narrative that immediately followed when the Total Float was actually generated the change to State or Contractor owned float based on entry of Actual Start and Actual Finish dates and percentage of work completed, and this must be agreed to by both parties in the next project Progress Meeting. Without this timely documentation any Total Float generated will be considered project float.

K. Progress Schedule Updates and Weekly Status Reports:

- 1) The Contractor shall perform a Progress Schedule Update on a minimum of a weekly basis, and every fourth schedule update period shall be consistent with monthly contract payment period.
- 2) The Contractor shall generate a Weekly Status Report after performing the Progress Schedule Update and Scheduling the project with a Data Date of day the schedule was updated, and submit it to the Engineer within one (1) State Business Day of the Data Date for that update period. The Weekly Status Report shall be generated using the activity Layout named Weekly Status Report, with activities grouped by the WBS, and using the standard default filter named Longest Path. The Gantt Chart shall clearly indicate the project critical (longest) path. Graphical representations shall be shown at a suitable scale to be legible and readable.
- 3) During any time periods within the contract that special time-related contract provisions are in effect, including B-Clock periods or Incentive/Disincentive Periods, the Engineer may require more frequent Progress Schedule Updates and/or Progress Schedule Status Reports.

METHOD OF MEASUREMENT:

The quantity shall be measured for payment on a Lump Sum basis.

The minimum lump sum bid for this item shall be the unit price shown in the itemized proposal.

Failure of the Contractor to bid at least the minimum amount will result in the Department adjusting the Contractor's bid to include the minimum bid amount for this item.

Item 639.1022 01 – CPM (CRITICAL PATH METHOD) PROGRESS SCHEDULES – TYPE 2

BASIS OF PAYMENT:

The lump sum price bid for CPM Progress Schedules shall include all labor, material, equipment, and incidentals, required to complete the work.

Progress payments will be made as follows:

- A. A total of twenty-five (25) percent will be paid upon achieving all of the following:
 - 1. Attendance at the Preconstruction Schedule Meeting
 - 2. Acceptance of the Baseline Progress Schedule @ Award.
 - 3. Acceptance of the Final Baseline Progress Schedule @ Award.
 - 4. Acceptance of the List of Submittals.
- B. A total of forty five (45) percent will be paid for acceptance of Monthly Progress Schedule submissions, acceptance of any necessary Time Impact Analysis, and acceptance of any necessary Recovery Schedules.

Progress payments for this item will be calculated by multiplying the Daily Payment Amount by the calendar days in the estimate period, less any deductions for unsatisfactory CPM Progress Schedules, Time Impact Analysis, or Recovery Schedules. The Daily Payment amount will be calculated by taking 45 percent of the total item cost divided by the number of calendar days in the contract duration as designated in the proposal, without regard to any extension of time.

- C. A total of twenty five (25) percent will be paid for submittal of Weekly Status Reports, participation in progress meetings, and submittal of Look-Ahead Schedules.
Progress payments for this item will be calculated by multiplying the Bi-weekly Payment amount by the number of Bi-weekly periods (1 or 2) in the estimate period, less any deductions for unsatisfactory Status Reports or Look-Ahead Schedules, or non attendance at progress meetings. The Bi-weekly Payment amount will be calculated by taking 25 percent of the total item cost divided by the number of bi-weekly periods in the contract duration as designated in the proposal, without regard to any extension of time
- D. A total of five (5) percent will be paid upon acceptance of the As-Built Progress Schedule.

Following notification by the Engineer that there are deficiencies in compliance with the specification requirements, as described in paragraph E.1, with the submittal of any Progress Schedule no payment will be made under CPM Progress Schedules for each calendar day during which those deficiencies continue to exist. The amount of such calendar day non-payment will be the Daily Payment Amount as calculated above multiplied by the number of days there are deficiencies in compliance with the specification requirements.

Non-refundable liquidated damages may be assessed for each subsequent calendar day or part thereof that a cited deficiency resulting in non-payment is not corrected or is permitted to recur. Non-refundable liquidated damages will be assessed at the rate equal to four times the Daily Payment Amount as calculated above.

In the event the contract completion date is extended, no additional payment will be made for CPM Progress Schedules for Non-compensable Delays. If the contract completion date is extended due to a Compensable Delay than payment for maintaining and submitting additional CPM Progress Schedules, Weekly Status Reports, and weekly Look-Ahead Schedules shall be equal to the Daily Payment Amount as calculated above multiplied by the number of calendar days the contract is extended plus the Bi-weekly Payment Amount multiplied by the number of bi-weekly periods the contract is extended.

Payment will be made under:

Item No.	Item	Pay Unit
639.1022 01	CPM (Critical Path Method) Progress Schedule – Type 2	LS